

- 1.0 GENERAL NOTES
  - 1.1 ALL METRIC DIMENSIONS ARE IN BRACKETS [X.XX]
  - 1.2 FOR PATENT INFO: <https://www.adwpat.com>

- 2.0 DESIGN NOTES
  - 2.1 ANY HAZARDS OR OBSTRUCTIONS TO THE CLIMBING FACILITY AND SAFETY CLIMB MUST BE IDENTIFIED PRIOR TO INSTALLING THE APPURTENANCE. ADDITIONAL PRODUCTS MAY BE REQUIRED TO MAINTAIN THE INTEGRITY OF THE SAFETY CLIMB. DURING INSTALLATION, TEMPORARY AND/OR PERMANENT PRECAUTIONARY MEASURES SHOULD BE TAKEN TO PRESERVE THE CLIMBING FACILITY AND/OR SAFETY CLIMB.
  - 2.2 UP TO 5.0° TAPER AVAILABLE ON MODELS THAT SUPPORT ADJUSTMENT.

- 3.0 MANUFACTURING/SPECIAL REQUIREMENTS
  - 3.1 TIGHTEN ALL BOLTS SECURING FLAT PLATES BY THE TURN-OF-NUT METHOD. TIGHTEN ALL U-BOLTS USING TURN-OF-NUT METHOD WITH ATTENTION TO LEAVE EQUAL DISTANCE AND EQUAL FORCE ON EACH LEG OF THE U-BOLT.

- 4.0 TEST
- 5.0 PACKAGING
  - 5.1 PACKAGING SHALL MEET ANDREW REQUIREMENTS PER DOCUMENT IS-PL-3005.
  - 5.2 PRINTED DOCUMENT TO BE PLACED INSIDE POLYBAG AND THEN IN SHIPPING CONTAINER.
  - 5.3 EXTRA HARDWARE MAY BE SUPPLIED, BAGGED AND SHIPPED.

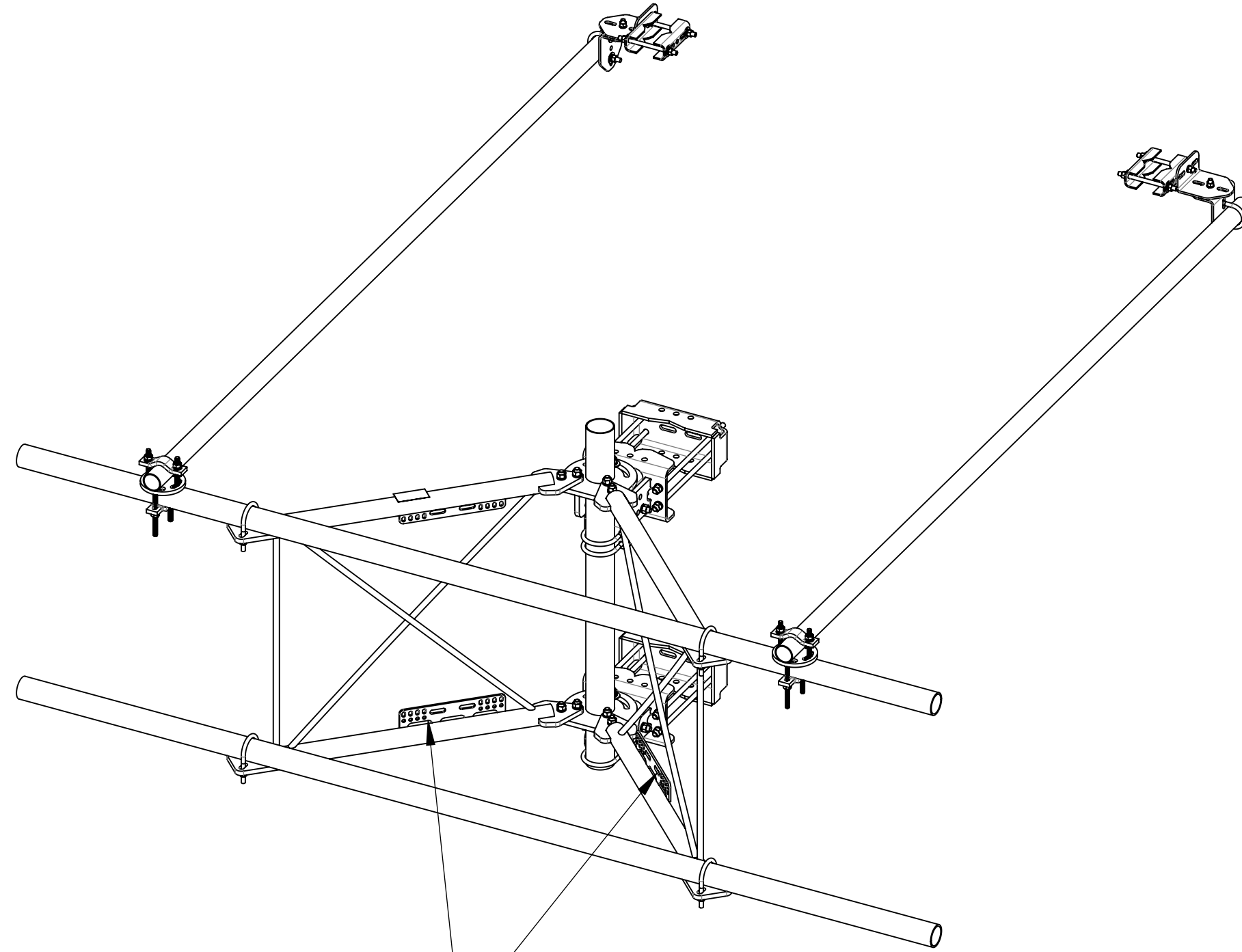

REVISIONS			
REV.	DESCRIPTION	DATE	APPROVED
H	TIE BACK WAS MT-651-120; ADDED 4X GUB-53560 FOR MONOPOLE VERSION	YX1027 14JUL22	BA1025 40152319CMO
J	REMOVED SFG2250, UPDATED NOTES	YMENG 18APR23	BA1025 40146772CMO
K	ADDED SFG2255	JL1183 05DEC23	YW1045 40184491CMO
L	SADDLE MOUNT CHANGED TO G23	YMENG 13JUN24	BA1025 40197994CMO
M	SFG2292-00(ITEM 2) WAS SFG2278; MT-651-120 (ITEM 24) WAS MT546120120; GUB-4240(ITEM 13) WAS GUB-4352; GUB-4352(ITEM 14) QTY 4 WAS 6; ADDED SHEET 5 V-ARM VIEW	JL1183 25NOV24	YZ1080 40209215CMO



SHOULD BE INSTALLED WITH UNIVERSAL INTERFACE PLATES FACING OUTWARDS



**ANDREW**® an Amphenol company

TOLERANCES		SAP MATERIAL MASTER				
0 PLACE X[X] ± 0.25[6.3]	2 PLACE .XX[X] ± 0.06[1.5]	<b>SFG22HDX-10-B</b>				
1 PLACE .X[X] ± 0.12[3.0]	ANGLES ± 2°					
FINISH		MATERIAL				
UNLESS OTHERWISE SPECIFIED DIMENSIONS ARE IN INCHES INTERPRET PER ANSI Y 14.5M-1994		NAME	DATE	<b>G22 SECTOR FRAME, 10' FACE, NS BASE KIT</b>		
		CE YMENG	03/17/2022			
		RW YX1027	06/09/2025			
		AD YMENG	06/09/2025			
		RE YMENG	06/09/2025			
ECN 40209215CMO		SCALE	DOCUMENT NO.			
		<b>1:16</b>	<b>SFG22HDX-10-B</b>			
SIZE	Auth Group	INSL	MODEL	DRAWING		SHEET 1 OF 7
<b>C</b>			VERSION STATUS REVISION	VERSION STATUS REVISION		
			05 RE M	05 RE M		

DENSITY		lbs/in³
MASS	472.15	lbs
VOLUME	1669.40	in³
SURFACE AREA	16280.80	in²
HEIGHT	47.88"	
LENGTH	126"	
WIDTH	120"	

Confidential

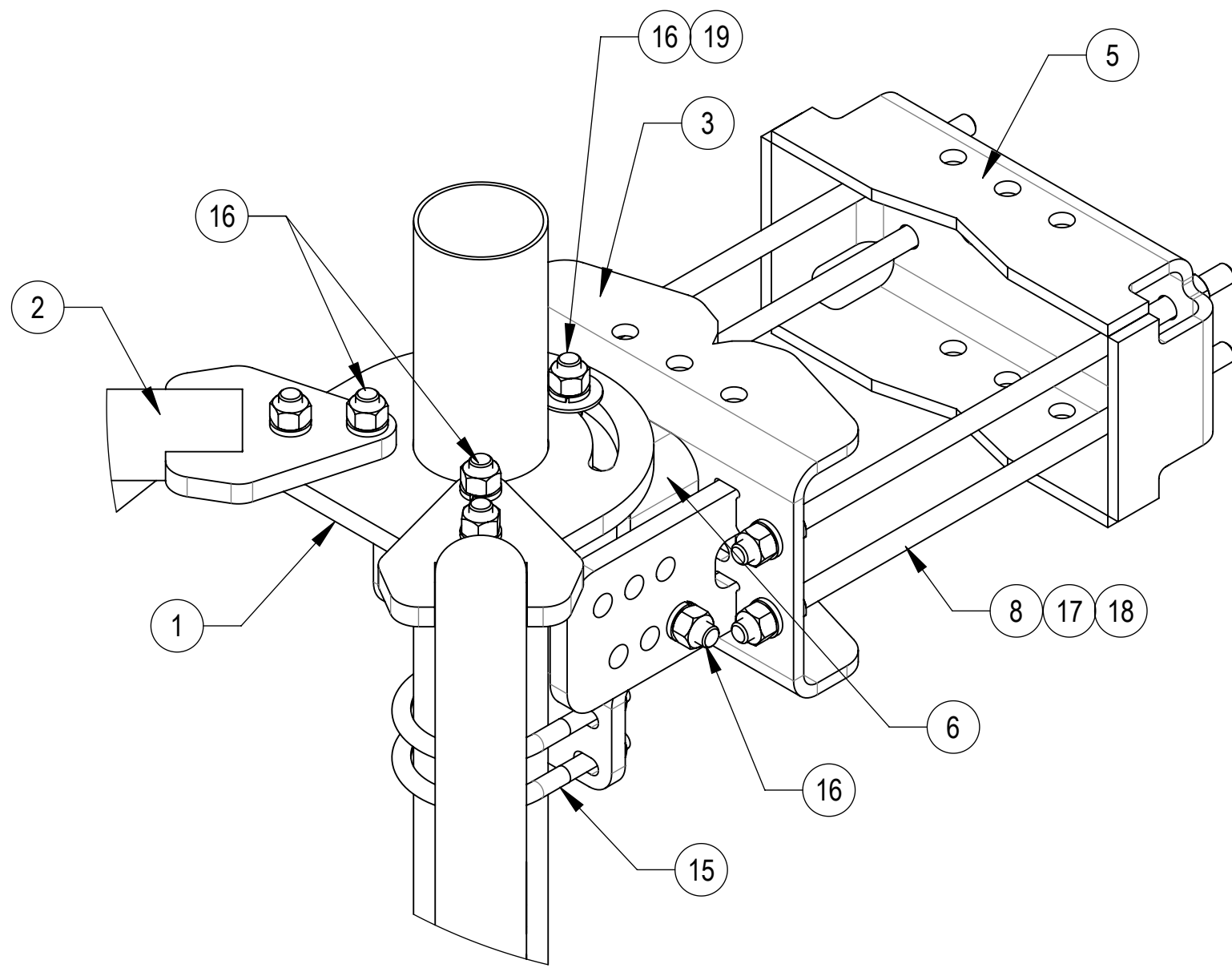

**DETAIL B**  
SCALE 1 : 4

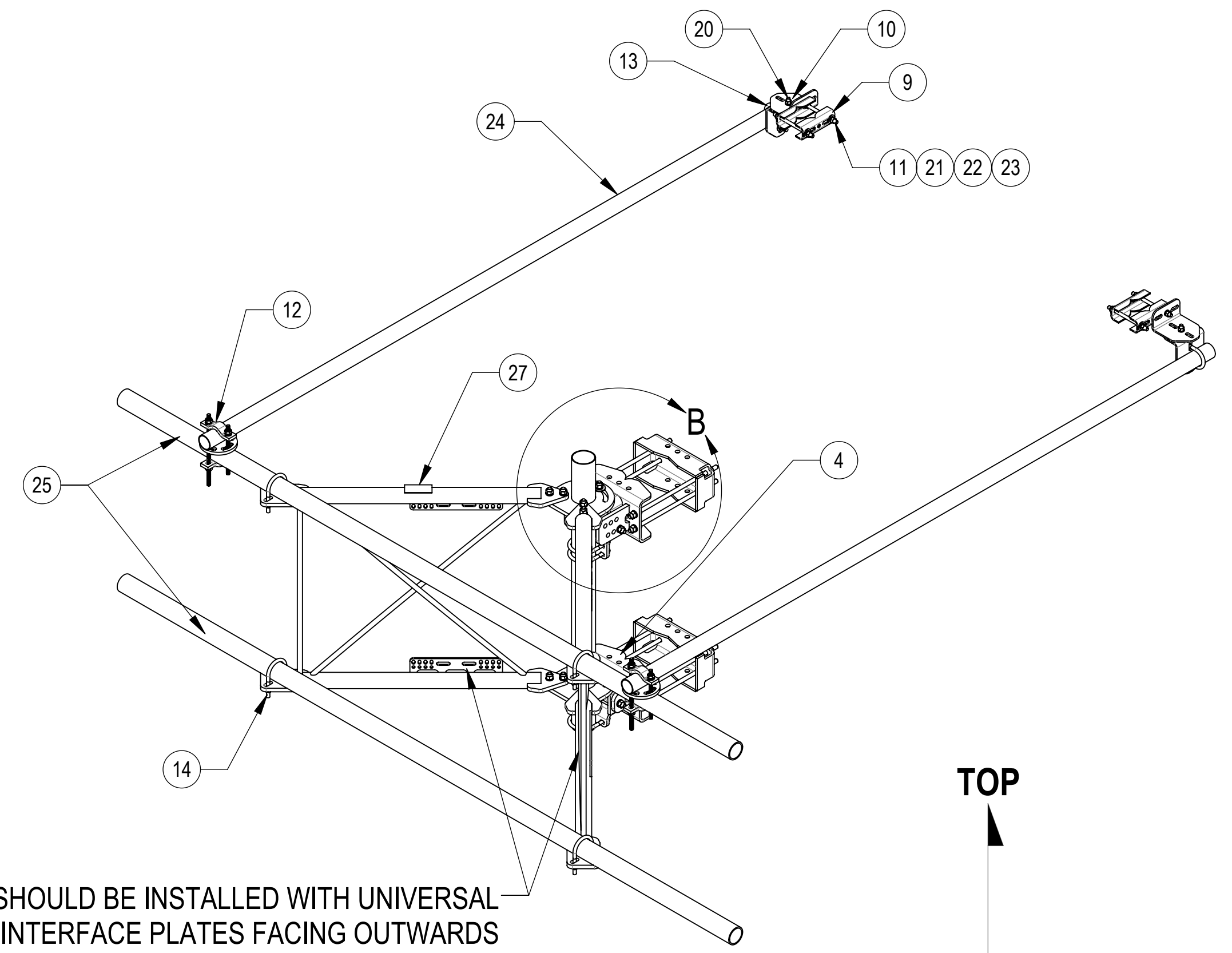

SHOULD BE INSTALLED WITH UNIVERSAL  
INTERFACE PLATES FACING OUTWARDS

**ALLOWABLE TIEBACK ANGLE**  
± 15 DEGREES VERTICAL  
± 25 DEGREES HORIZONTAL

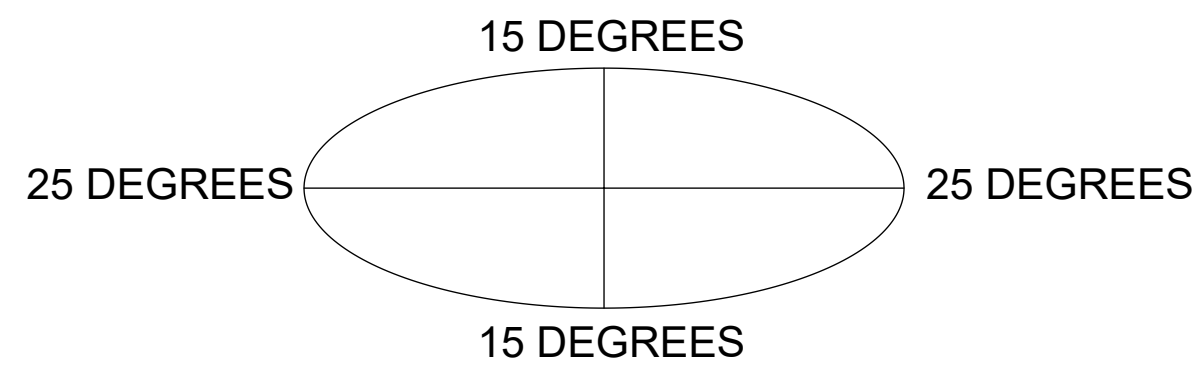

COMPONENT PART NUMBERS PROVIDED FOR ASSEMBLY PURPOSES;  
INDIVIDUAL COMPONENTS MAY BE SHIPPED AS PARTS WITHIN AN INCLUDED KIT.

ITEM	PART NO.	DESCRIPTION	QTY.	WEIGHT	NOTE NO.
1	SFG2270	BACK VERTICAL ARM MOUNT	1	36.96 LBS	
2	SFG2292-00	WELDMENT, V-ARM, SECTOR FRAME 22	2	49.69 LBS	
3	SFG2380	WELDMENT, HD, TOP TAPER BRACKET	1	22.78 LBS	
4	SFG2381	WELDMENT, HD, LOWER TOWER LEG BRACKET	1	17.42 LBS	
5	SFG2289	G2 RRU BACK CLAMP, HD	2	18.65 LBS	
6	SFG2386	WELDMENT, SFG2 AZIMUTH BRACKET	1	10.07 LBS	
7	SFG2397-00	WELDMENT, G23 AZIMUTH BRACKET	1	7.94 LBS	
8	MT-382-18	5/8" X 18" THREADED ROD	8	1.43 LBS	
9	SAB01	FORMED CLAMP	4	1.35 LBS	
10	XAU01	ANGLE, CROSSOVER, 1.9-3.5" X 1.9-3.5" OD	4	2.98 LBS	
11	MT-379-8	1/2" X 8" GALV THREADED ROD	4	0.45 LBS	
12	XP-R	CROSSOVER PLATE, ROUND, UP TO 3.5" OD	2	6.20 LBS	
13	GUB-4240	1/2" X 2-1/2" X 4" GALV U-BOLT	2	0.56 LBS	
14	GUB-4352	1/2" X 3" X 5-1/4" GALV U-BOLT	4	0.71 LBS	
15	GUB-4355	1/2" X 3-5/8" X 5" GALV U-BOLT	3	0.71 LBS	
16	GB-05225	5/8" X 2-1/4" GALV BOLT KIT	14	0.28 LBS	
17	GN-05	5/8" GALV HEX NUT	24	0.08 LBS	
18	GWL-05	5/8" GALV LOCK WASHER	16	0.03 LBS	
19	GWF-05	5/8" GALV FLAT WASHER, 1.7OD	2	0.06 LBS	
20	GB-04145	1/2" X 1-1/2" GALV BOLT KIT	2	0.13 LBS	
21	GN-04	1/2" GALV HEX NUT	10	0.04 LBS	
22	GWL-04	1/2" GALV LOCK WASHER	10	0.01 LBS	
23	GWF-04	1/2" GALV FLAT WASHER	8	0.04 LBS	
24	MT-651-120	PIPE, 2.375"OD X 120"	2	29.07 LBS	
25	MT-546-126	PIPE, 2.875"OD X 126"	2	61.05 LBS	
26	GUB-53560	5/8" X 3-5/8" X 6" GALV U-BOLT	4	1.30 LBS	FOR RING MOUNT ONLY
27	SFG2255	LABEL, SFG21HDX	1	0.04 LBS	

**ANDREW** an Amphenol company

TITLE  
G22 SECTOR FRAME, 10' FACE, NS BASE KIT

SIZE <b>C</b>	SCALE <b>1:16</b>	DOCUMENT NO. SFG22HDX-10-B
DRAWING		SHEET
VERSION 05	STATUS RE	REVISION <b>M</b>
		2 OF 7

Confidential

4

3

2

1

TIEBACK MUST BE CONNECTED TO A RIGID MEMBER THAT PROVIDES ADEQUATE SUPPORT WITHIN THE LIMITS NOTED IN THE TIEBACK ANGLE RANGE DETAIL. UNLESS APPROVED BY ENGINEER OF RECORD. SPINE STEM OF NEIGHBORING MOUNT IS ACCEPTABLE.

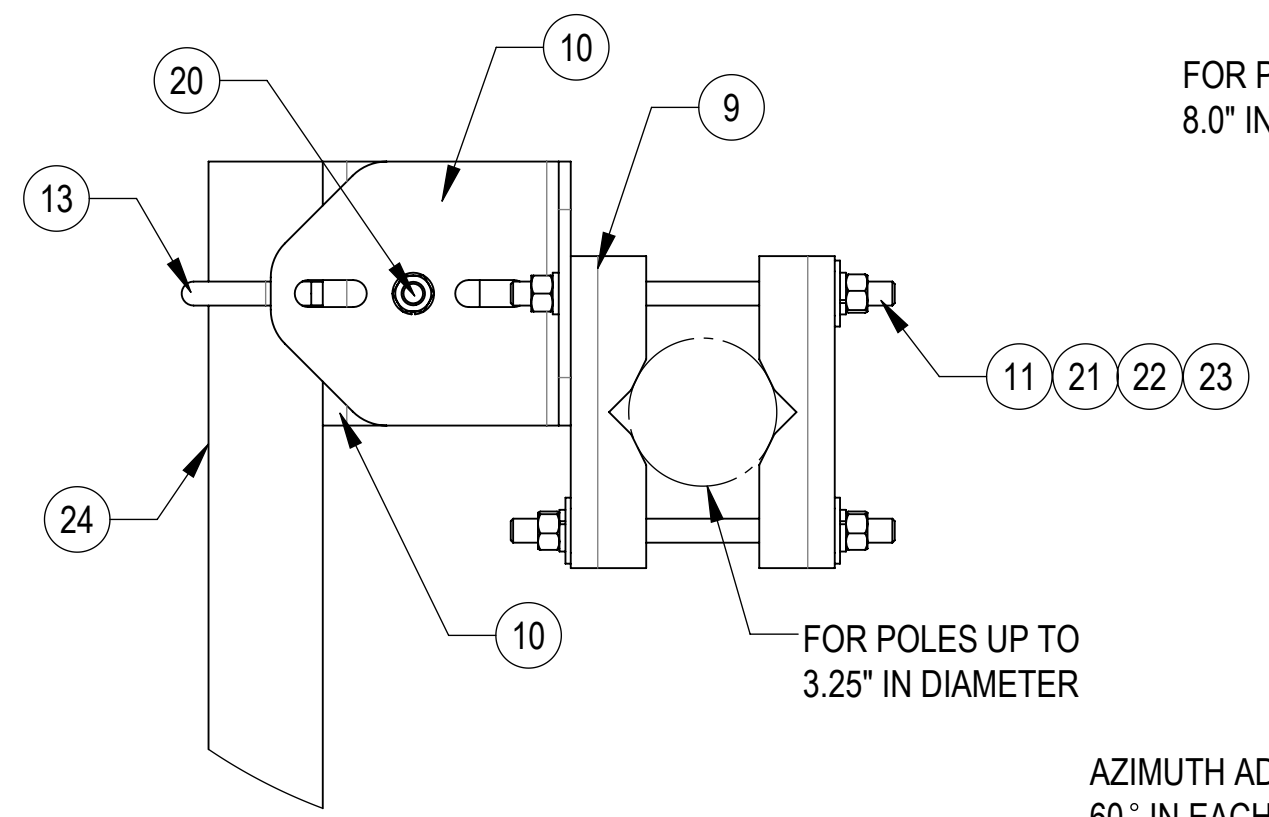
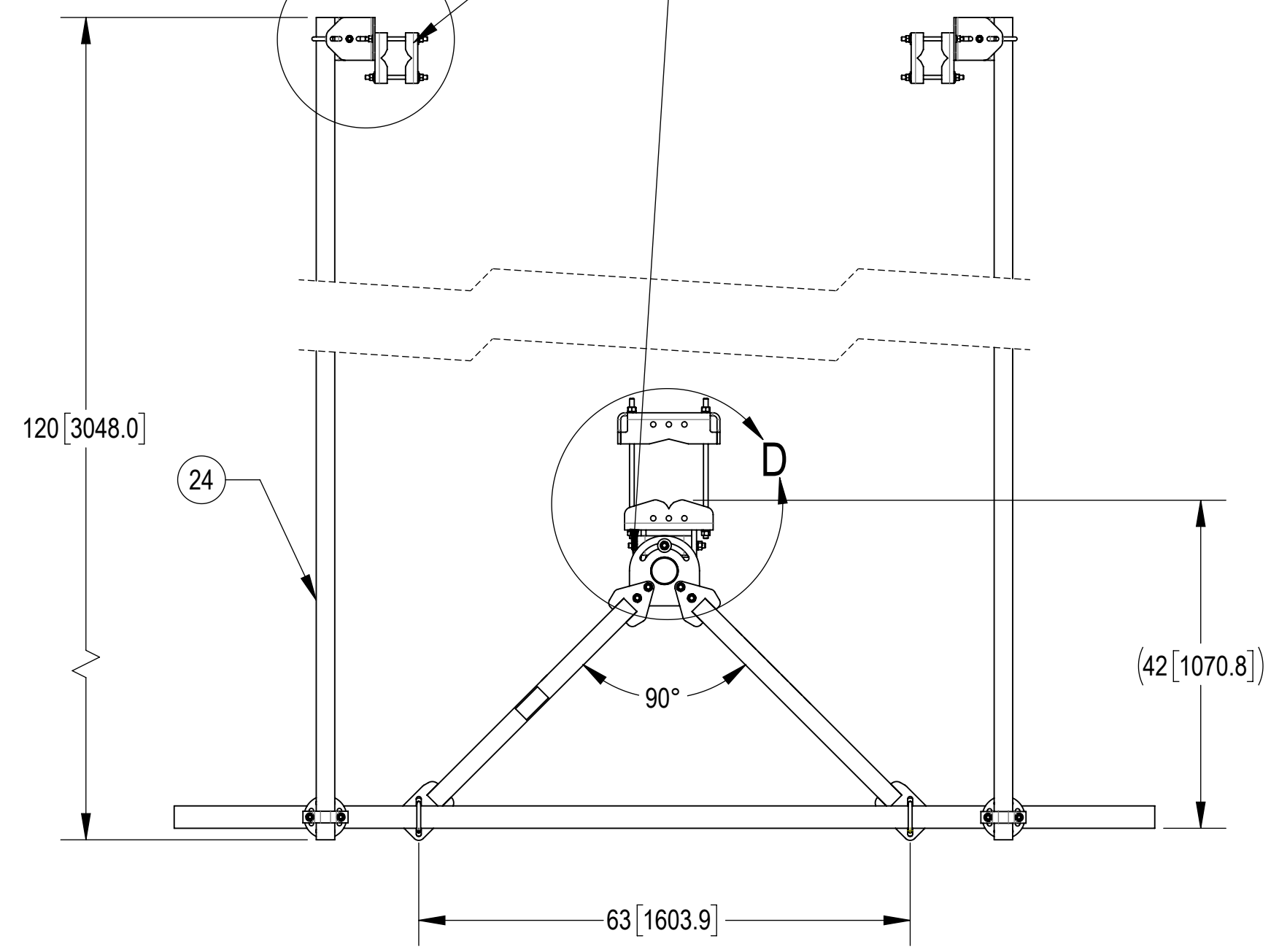

**DETAIL C**  
SCALE 1 : 4

FOR POLES UP TO 8.0" IN DIAMETER

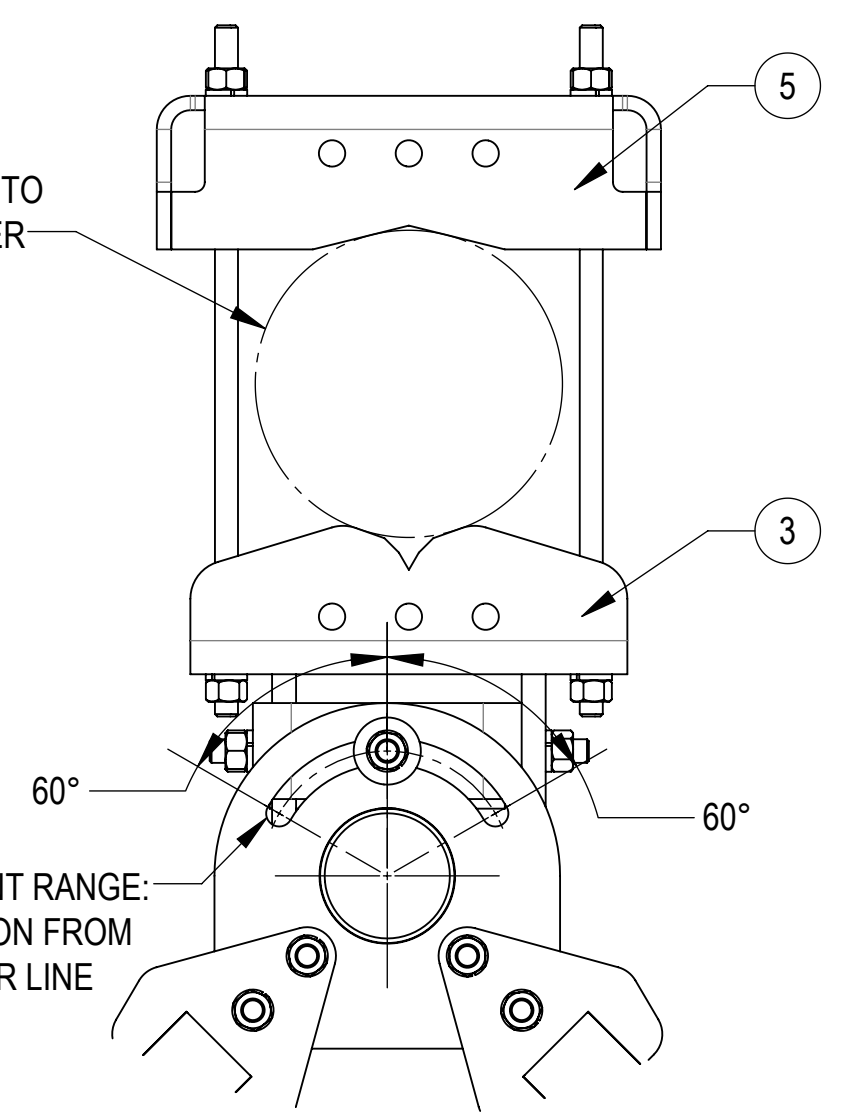

**DETAIL D**  
SCALE 1 : 5

**ALLOWABLE TIEBACK ANGLE**  
± 15 DEGREES VERTICAL  
± 25 DEGREES HORIZONTAL

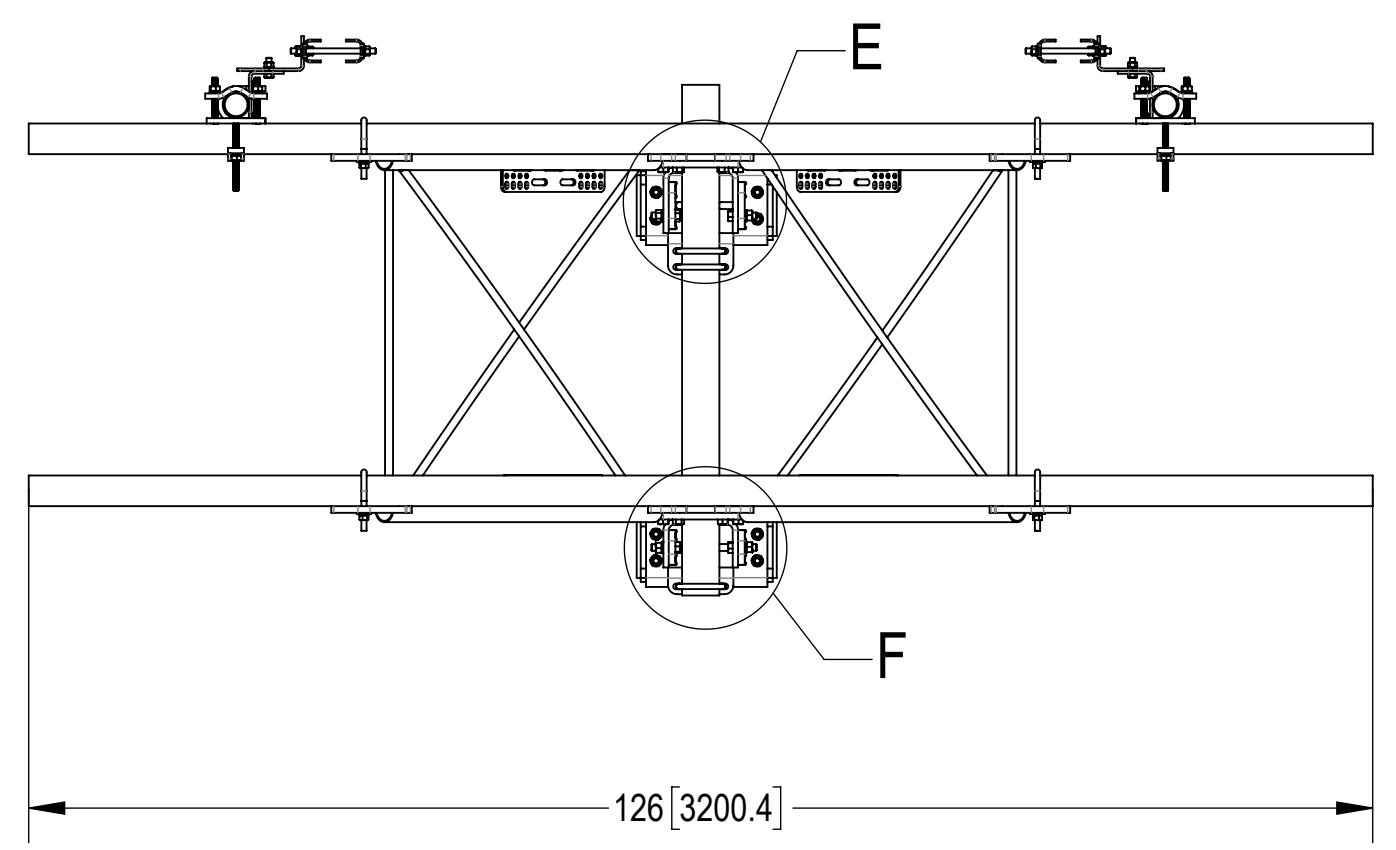
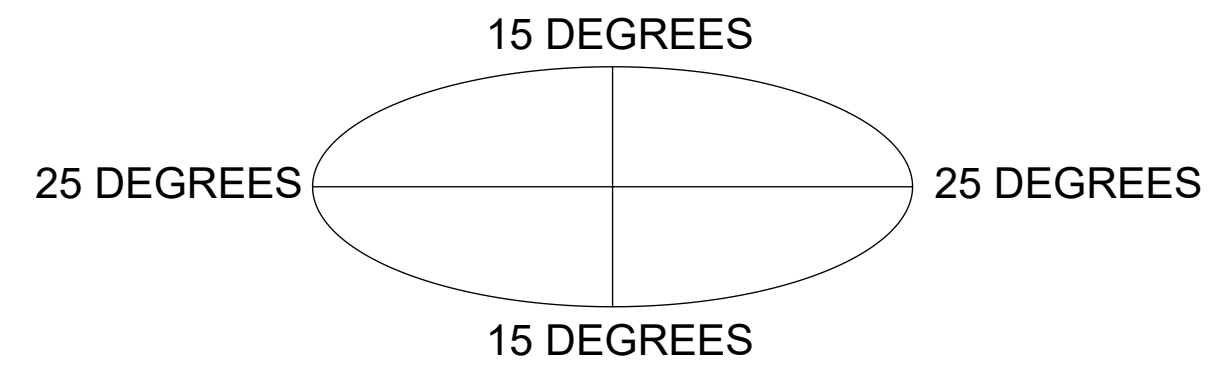

**TOP**  
↑  
**BOTTOM**  
↓

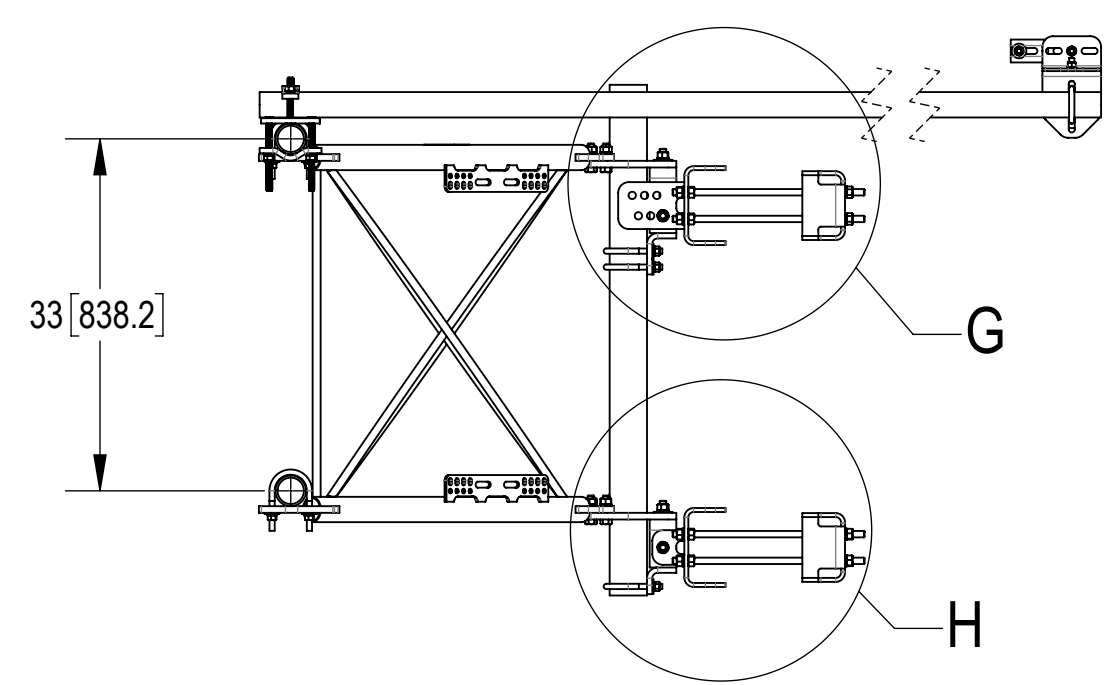

TITLE				
G22 SECTOR FRAME, 10' FACE, NS BASE KIT				
SIZE	SCALE	DOCUMENT NO.		
<b>C</b>	<b>1:18</b>	SFG22HDX-10-B		
		DRAWING		SHEET
		VERSION	STATUS	REVISION
		05	RE	M
				SHEET
				3 OF 7

Confidential

4

3

2

1

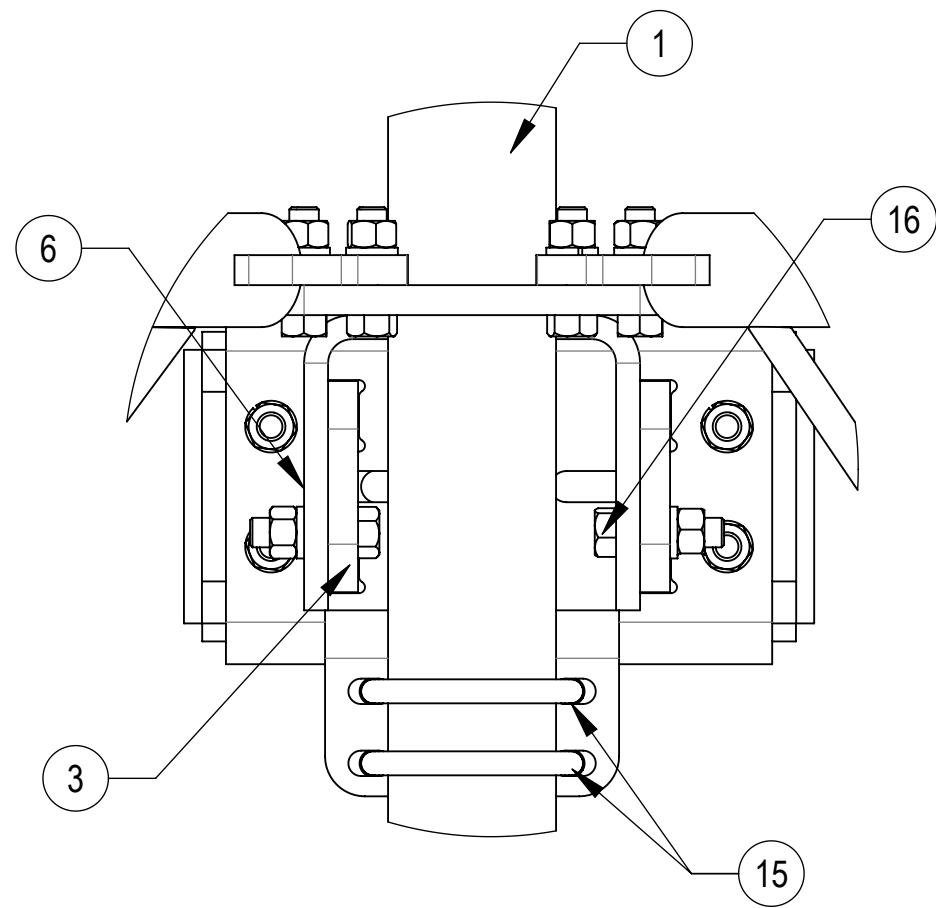

**DETAIL E**  
SCALE 1 : 4

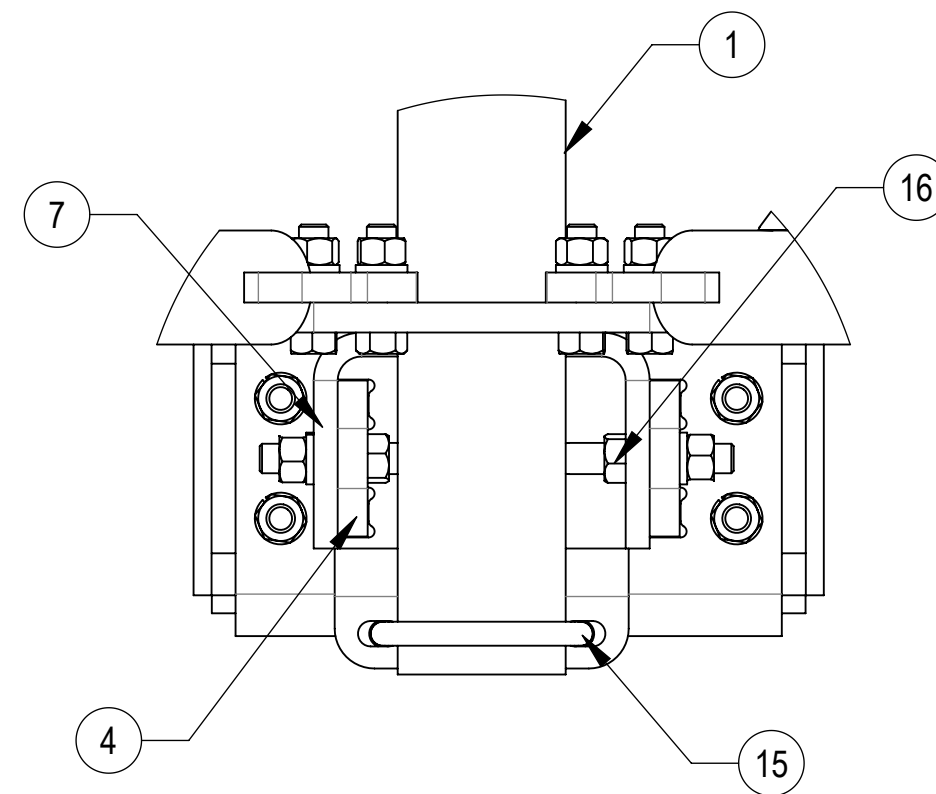

**DETAIL F**  
SCALE 1 : 4

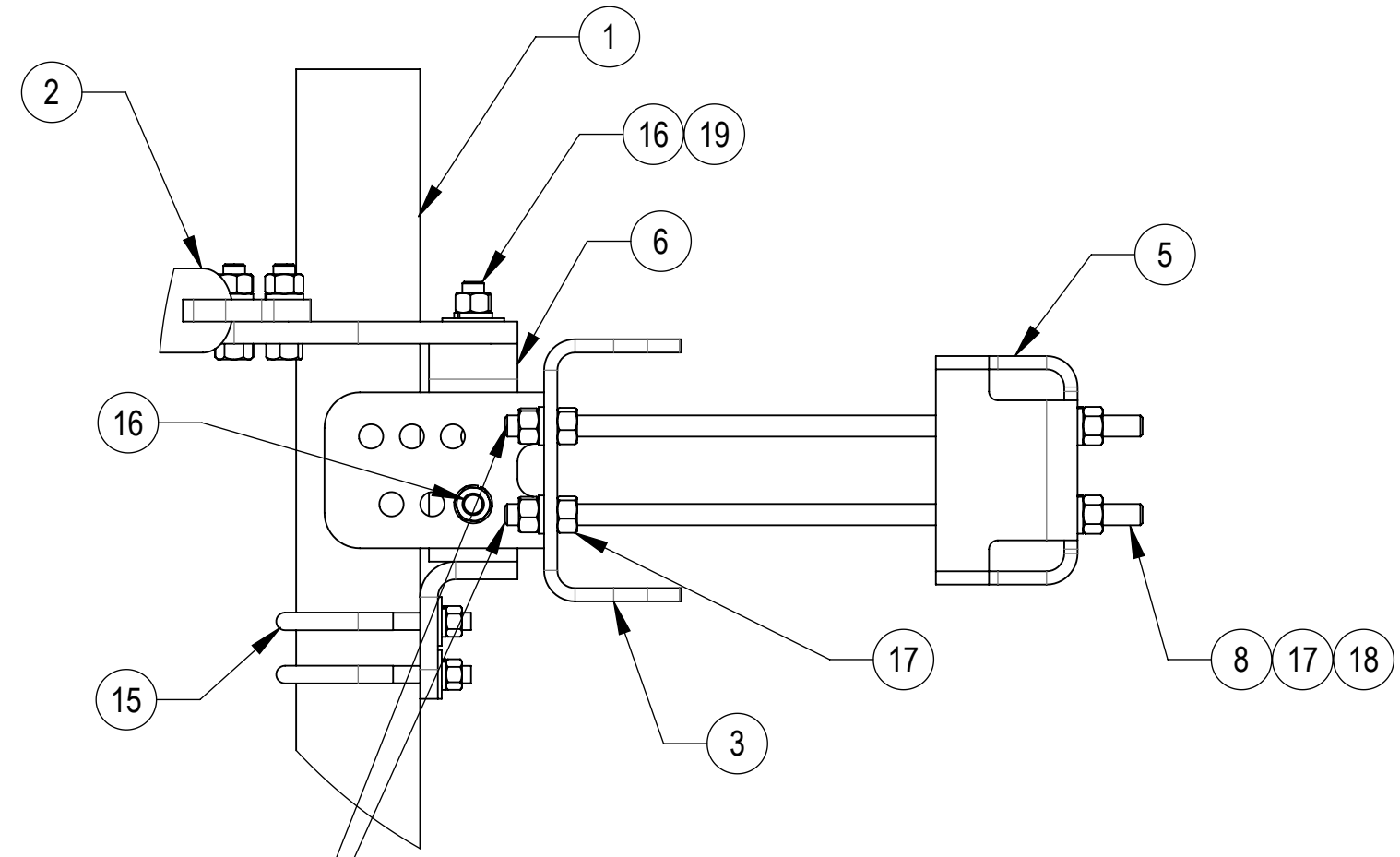

**DETAIL G**  
SCALE 1 : 5

THE THREADED ROD CAN ONLY EXPOSE 4 TO 7 THREADS ON ONE SIDE OF THE BRACKET, WHICH IS TO PREVENT INTERFERENCE WITH THE SIDE BOLTS

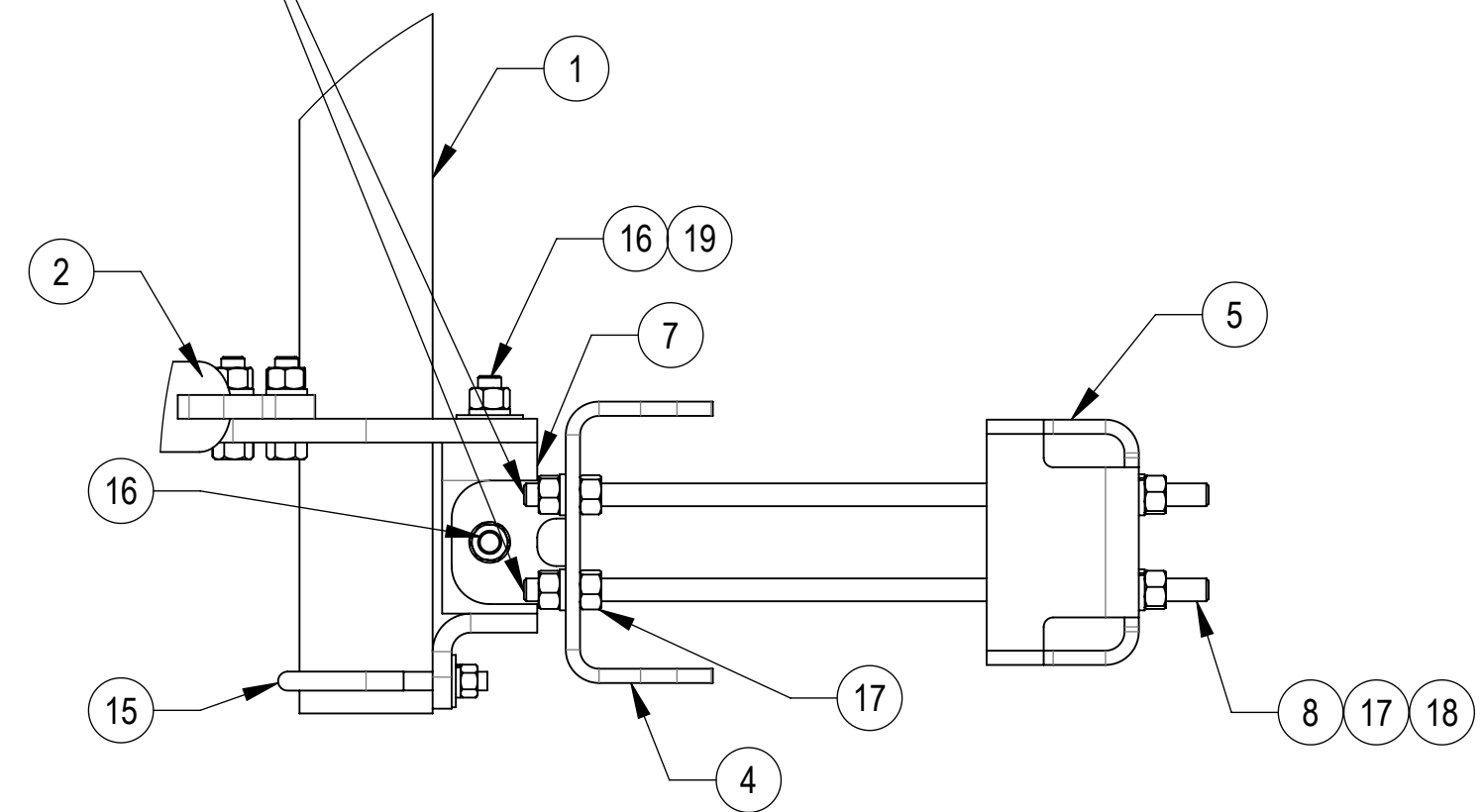

**DETAIL H**  
SCALE 1 : 5



TITLE  
**G22 SECTOR FRAME, 10' FACE, NS BASE KIT**

SIZE <b>C</b>	SCALE <b>1:18</b>	DOCUMENT NO. <b>SFG22HDX-10-B</b>
------------------	----------------------	--------------------------------------

DRAWING			SHEET 4 OF 7
VERSION	STATUS	REVISION	
05	RE	M	

Confidential

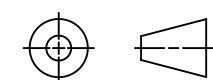

4

3

2

1

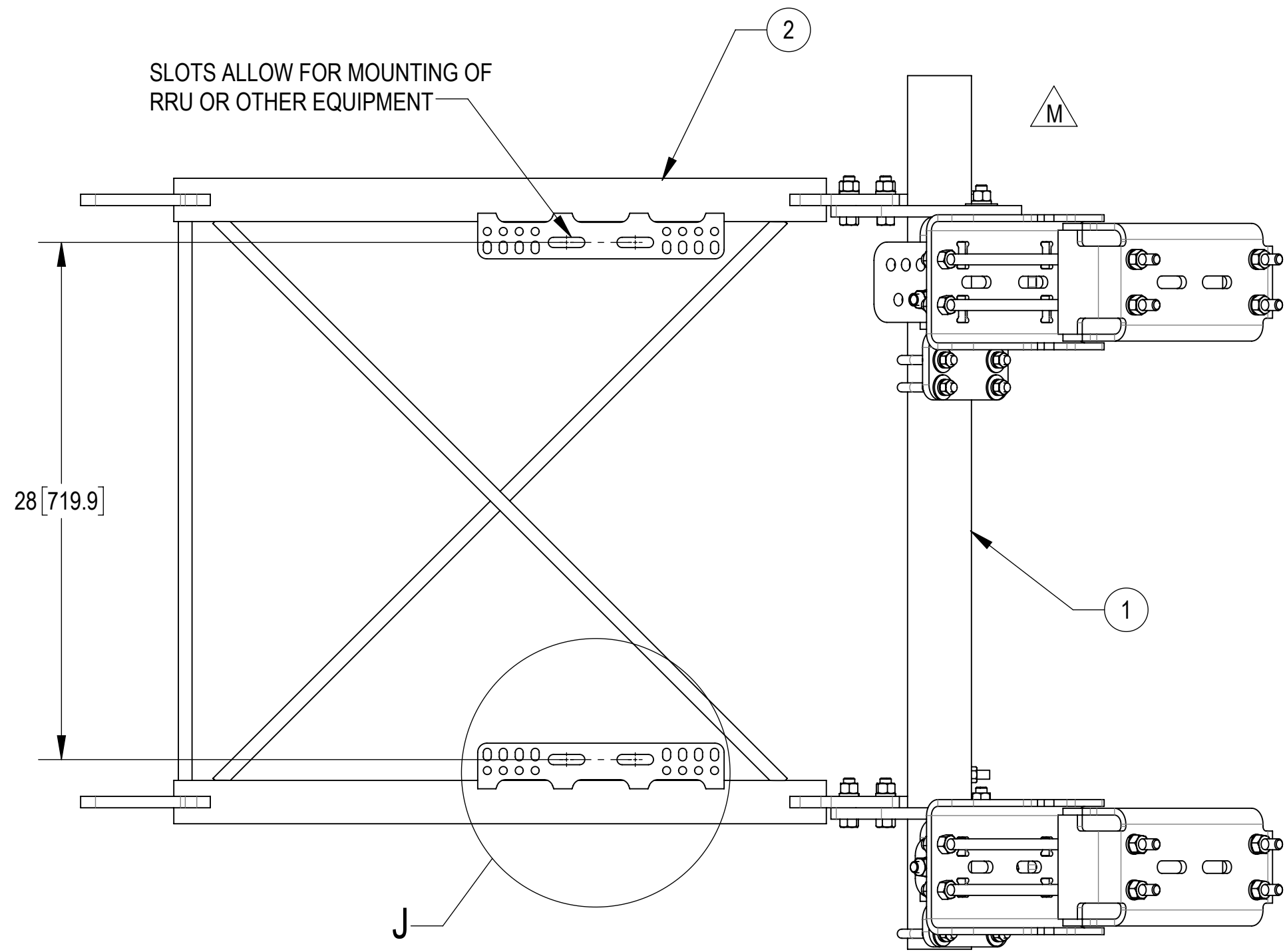

SIDE VIEW

SLOTS ALLOW FOR MOUNTING OF RRU OR OTHER EQUIPMENT

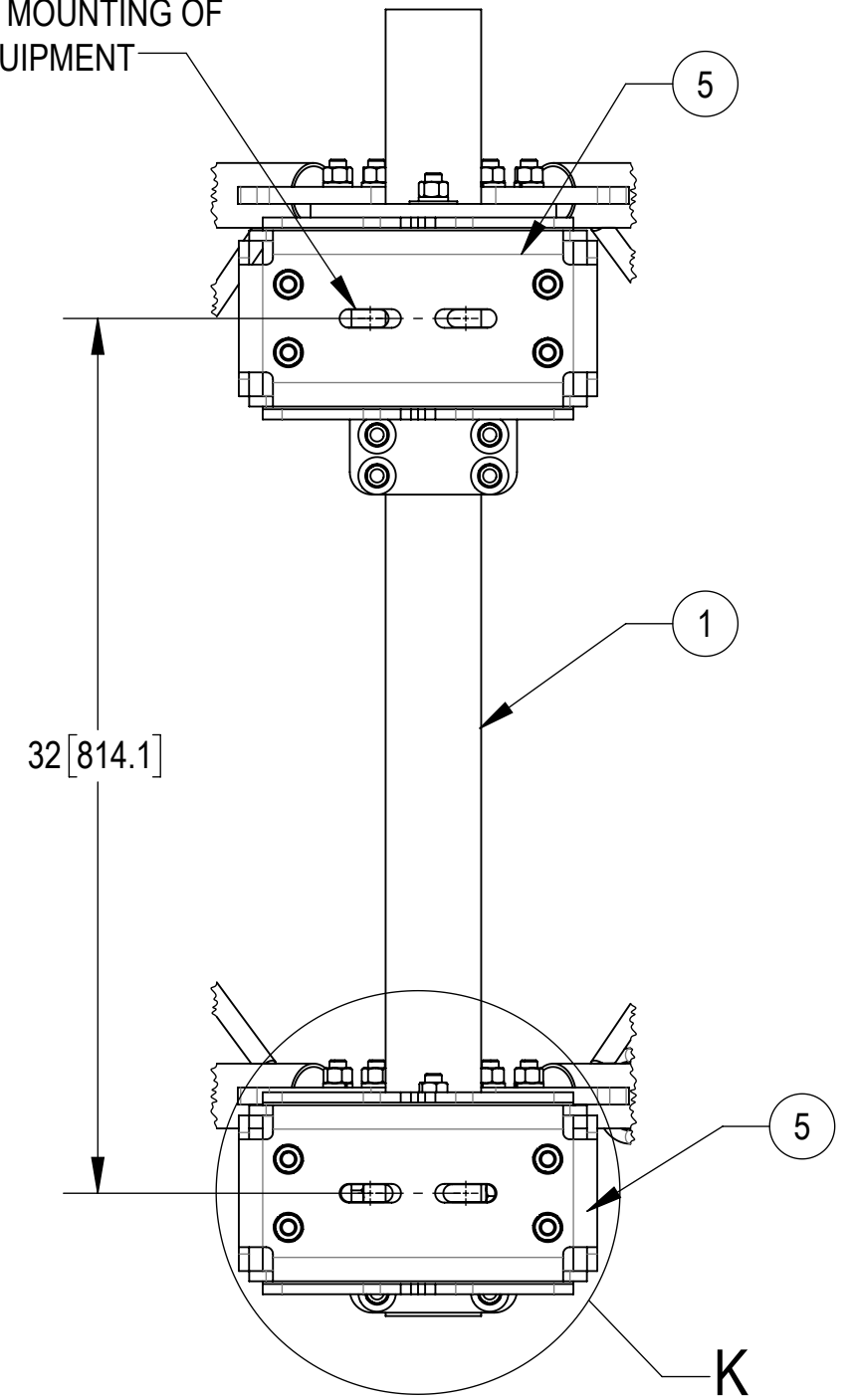

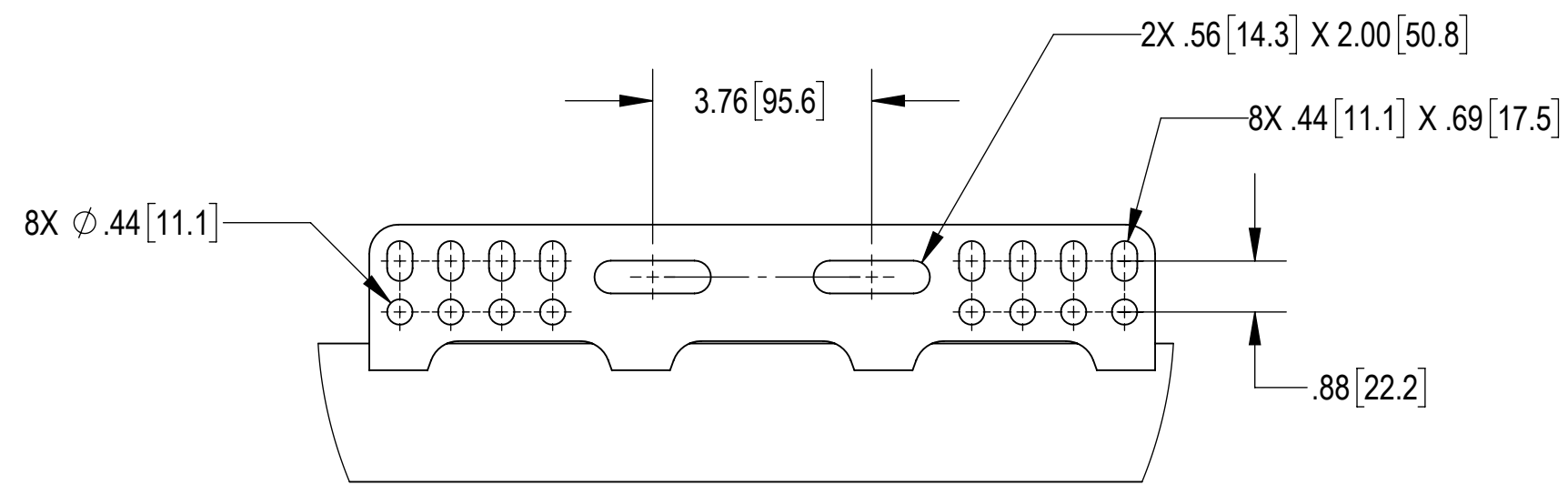

BACK CROP VIEW

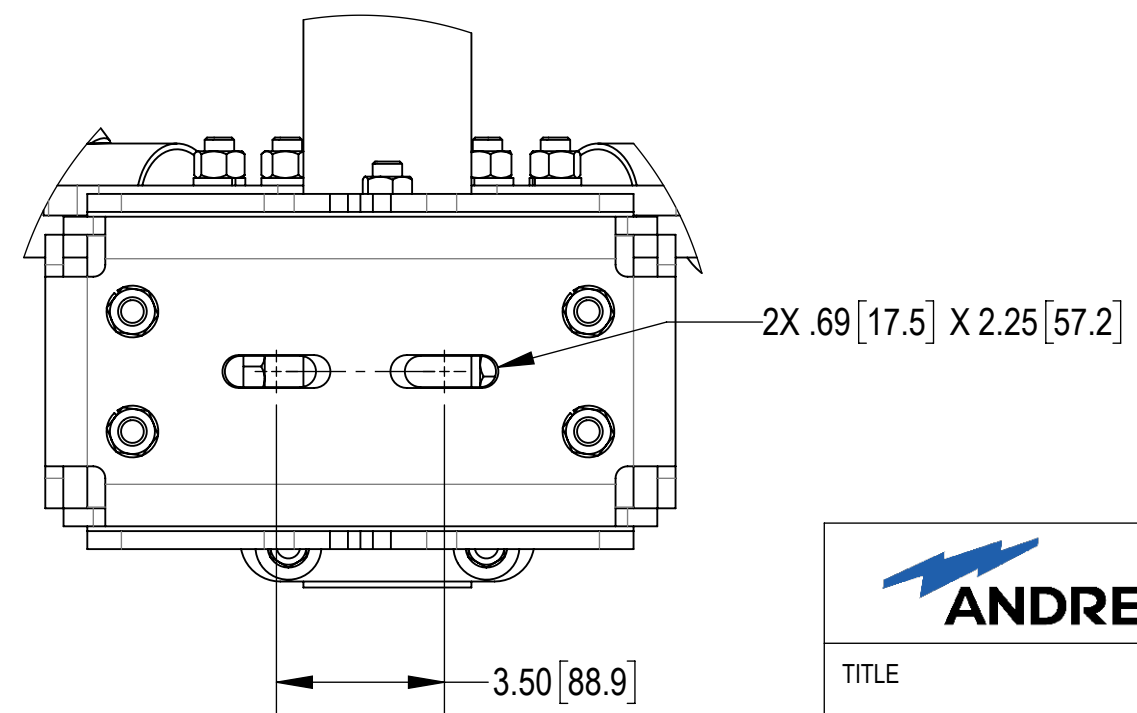

DETAIL J  
SCALE 1 : 3

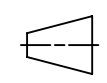

DETAIL K  
SCALE 1 : 4

 <b>ANDREW</b> an Amphenol company				
TITLE G22 SECTOR FRAME, 10' FACE, NS BASE KIT				
SIZE <b>C</b>	SCALE <b>1:18</b>	DOCUMENT NO. SFG22HDX-10-B		
 		DRAWING		SHEET 5 OF 7
		VERSION 05	STATUS RE	

Confidential

4

3

2

1

4

3

2

1

### OPTIONAL ACCESSORIES:

RING MOUNT KIT FOR MONOPOLE INSTALLATION (SOLD SEPERATELY)

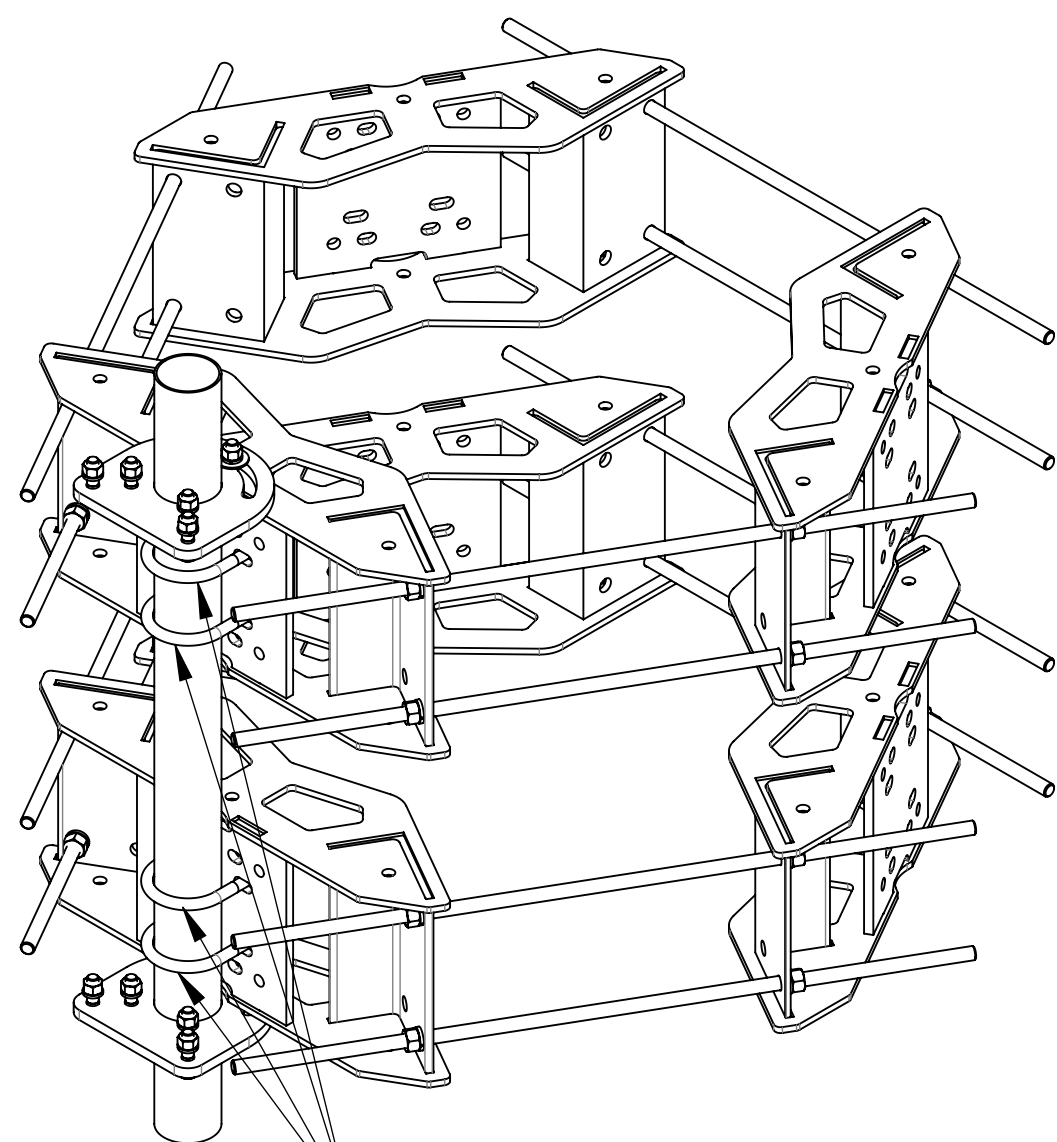

26 GUB-53560 (USE ON MONOPOLE VERSION ONLY)

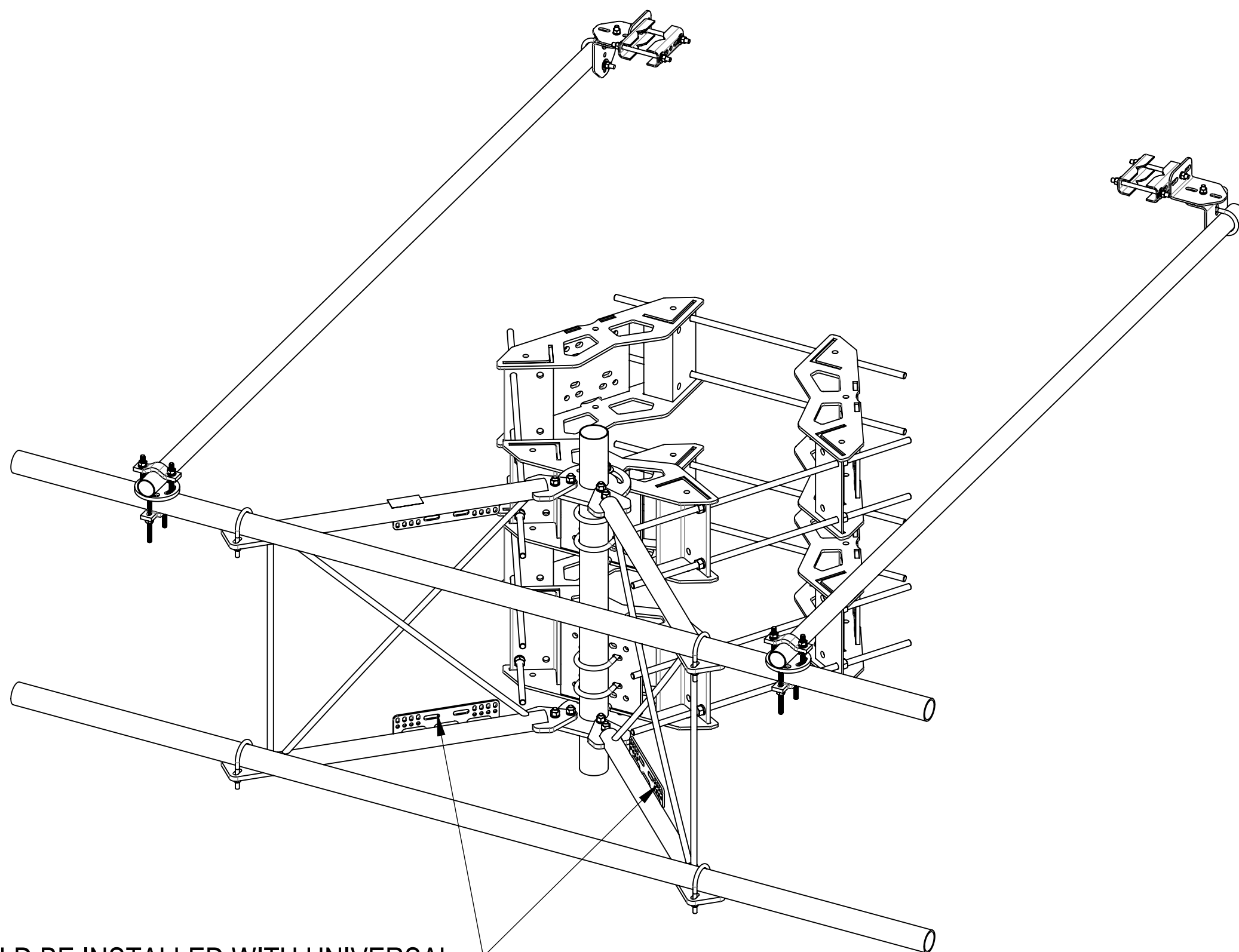

SHOULD BE INSTALLED WITH UNIVERSAL INTERFACE PLATES FACING OUTWARDS

### ALLOWABLE TIEBACK ANGLE

±15 DEGREES VERTICAL  
±25 DEGREES HORIZONTAL

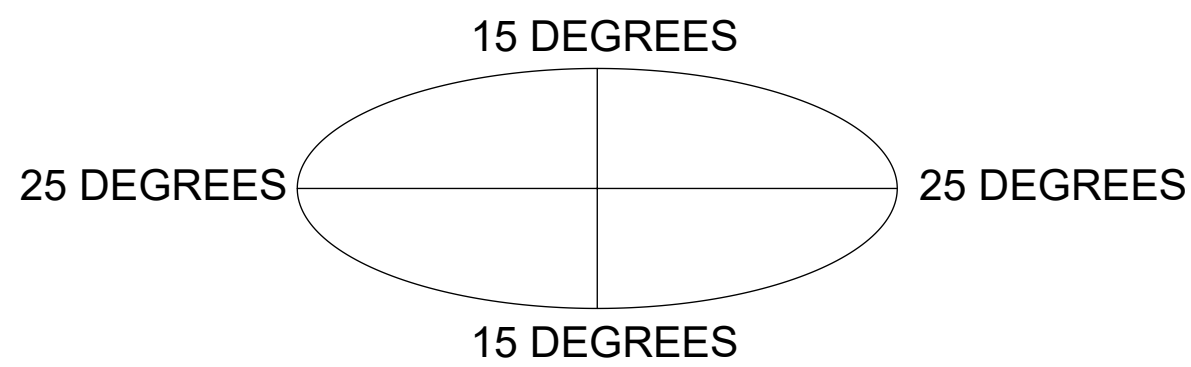

TITLE  
G22 SECTOR FRAME, 10' FACE, NS BASE KIT

SIZE <b>C</b>	SCALE <b>1:14</b>	DOCUMENT NO. SFG22HDX-10-B
------------------	----------------------	-------------------------------

	DRAWING			SHEET 6 OF 7
	VERSION 05	STATUS RE	REVISION M	

Confidential

4

3

2

1

D

D

C

C

B

B

A

A

4

3

2

1

**OPTIONAL ACCESSORIES:**

BUS BAR MOUNT KIT GBSF238 IS WELL SUITED TO BE USED SHOULD THE NEED ARISE  
NOTE THAT THIS KIT DOES NOT INCLUDE THE ISOLATORS OR BUS BAR

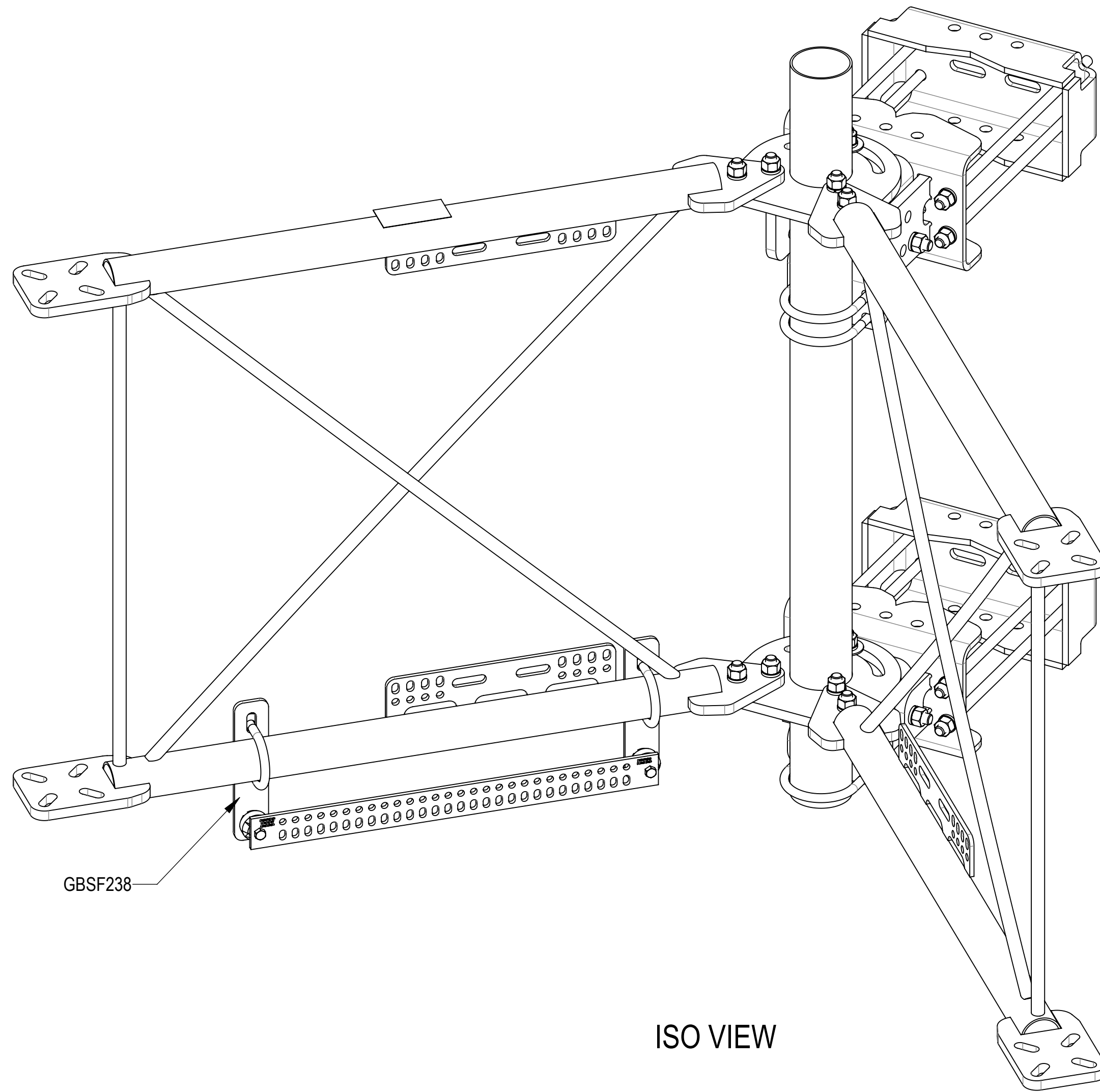



ISO VIEW

**ANDREW** an Amphenol company

TITLE  
G22 SECTOR FRAME, 10' FACE, NS BASE KIT

SIZE <b>C</b>	SCALE <b>1:6</b>	DOCUMENT NO. SFG22HDX-10-B
------------------	---------------------	-------------------------------

 	DRAWING			SHEET 7 OF 7
	VERSION 05	STATUS RE	REVISION M	

Confidential

4

3

2

1

D

D

C

C

B

B

A

A