

Application

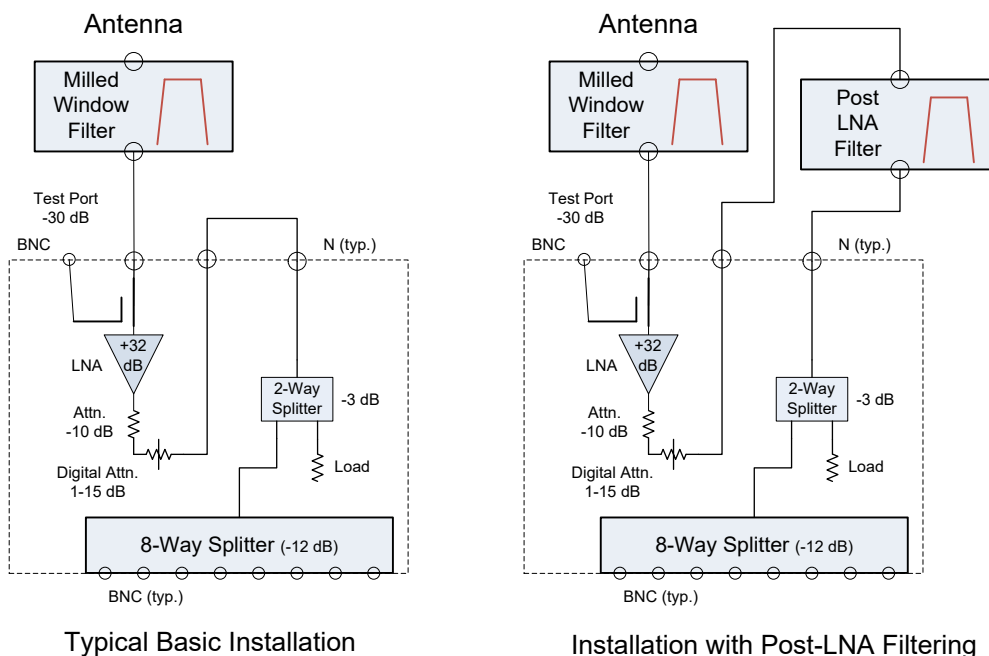

Any receiver multicoupler (RMC) installation must always include filtering between the antenna and the RMC since the RMC is a wide-band device.

In situations where additional RF selectivity is needed to eliminate interference, additional filtering can be added to the RMC using the filter ports on the rear panel (labeled RF IN and RF OUT). As shown in the diagram above, the second filter is placed after the LNA in the RMC. Because it is placed after the LNA, the additional loss of the post-filter has minimal impact on system noise figure and therefore receiver sensitivity.

Field Modification Kits

Model	Description
DSRMC06-EXP	8-Channel Expansion Kit – Includes splitter and cable assembly to expand an 8-channel RMC to 16-channel capacity.
DSRMC06DCKIT	DSRMC06 AC to DC Modification Kit – Order to field modify an AC version to the DC version. Contains DC-DC power supply, parts and cabling necessary to complete the conversion in the field.
DSRMC06ACKIT	DSRMC06 DC to AC Modification Kit – Order to field modify a DC version to the AC version. Contains AC-DC power supply, parts and cabling necessary to complete the conversion in the field.