

HPM 18-30

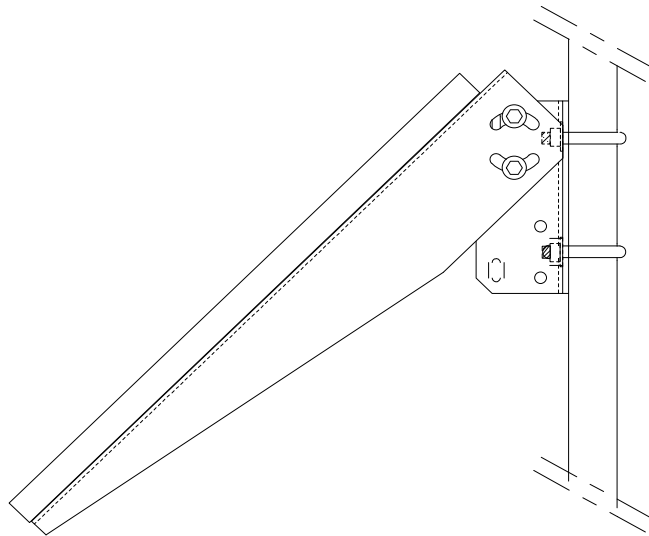
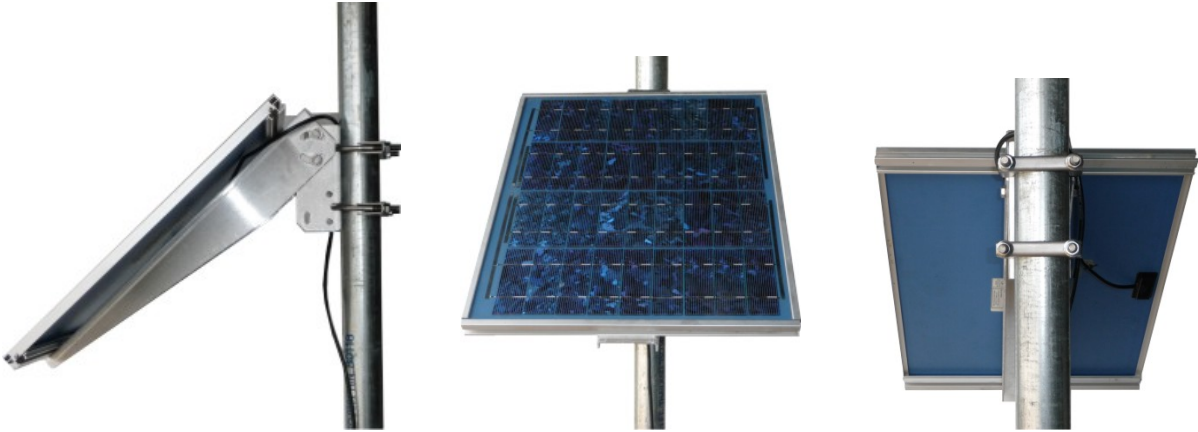

ASSEMBLY INSTRUCTIONS FOR SINGLE MODULE MOUNTING KIT
KIT NUMBERS

HPM 18-30

CONTENTS

<u>ITEM NO</u>	<u>PARTS LIST</u>	<u>QUANTITY</u>		<u>STOCK NO</u>
		HPM 18-30	HPM 5-10H	HPM 5-10
1	Mounting Bracket Adj.	----		
2	Bracket Adjustable	1		
3	Mounting Bracket / Flat	1		
4	Nut, Hex 5/16 –18	6		
5	Washer, Split Lock 5/16	6		
6	Washer, Flat 5/16	10		
7	Screw, 5/16-18 x 1 inch	6		

Before beginning assembly, check the parts list to make sure the kit contains all the right parts.

Tools Needed : One (1) Adjustable Wrench
 One (1) ½" Wrench

INTRODUCTION

The purpose of the assembly is to mount a solar module to a vertical pole or wall. Alternatively, the modules could also be mounted on square poles and other flat surfaces, both vertical and horizontal.

ASSEMBLY INSTRUCTIONS

Read these instructions thoroughly before starting assembly. Use the drawing below for reference for pole mounting.

Design Approach.

Mounting hardware for the SX 20 / 30 / 40 / 50 type solar panels has been designed to facilitate a wide variety of attachment methods, making these units highly adaptable to a range of needs. The MOUNTING BRACKET accepts horizontal mounting (as on a roof), vertical mounting (as on a external wall), or pole mounting. Any desired angle of inclination can be achieved by loosening the four bolts, which attach the MOUNTING BRACKET to the PANEL BRACKET, rotating the panel to the desired angle, and retightening the bolts.



HPM 18-30

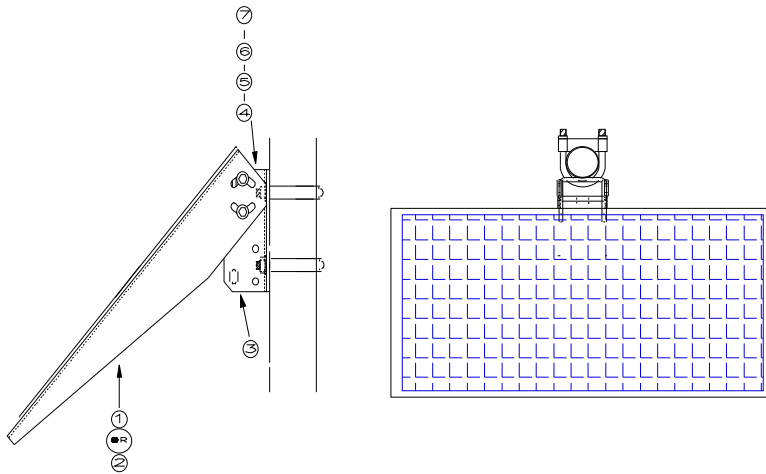

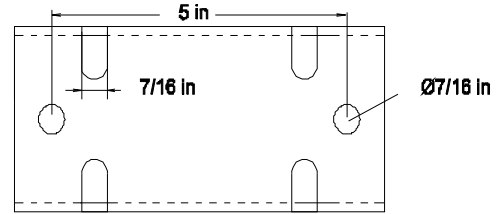
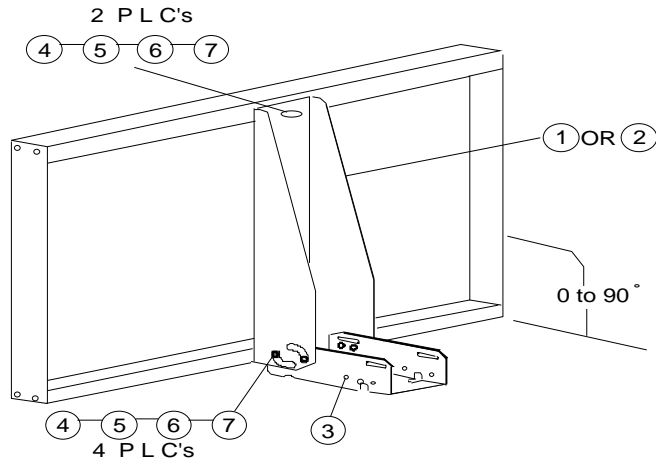

Hole Pattern in Base Of Mounting Bracket

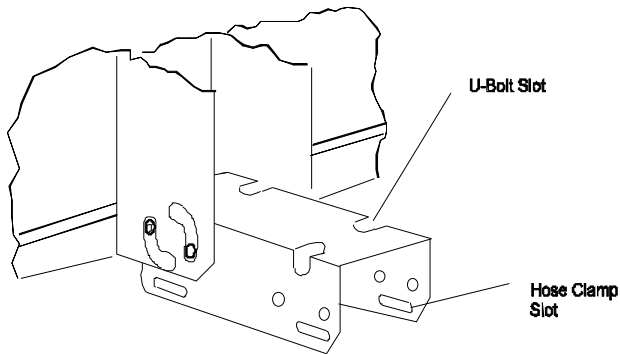

Mounting Bracket Mat Be Assembled To Panel Bracket Two Ways As Shown (Rotate End For End).

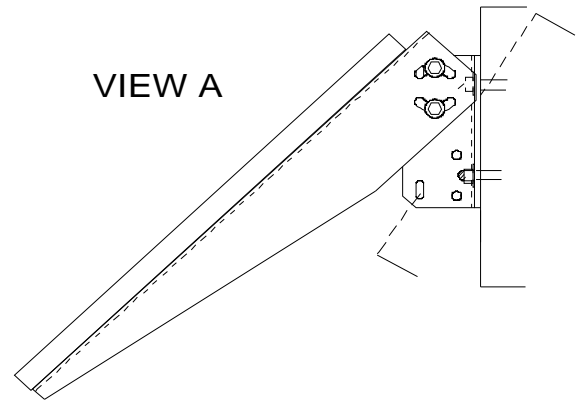

Mounting On Vertical Or Steeply Sloping Flat Surface Using (2) Lag Screws Or Bolts.

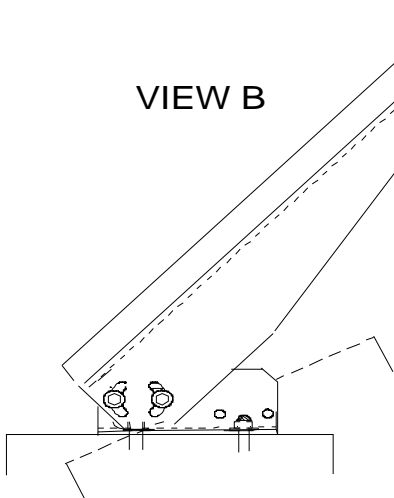

Mounting On Horizontal To Moderately Sloping Flat Surface Using (2) Lag Screws Or Bolts.

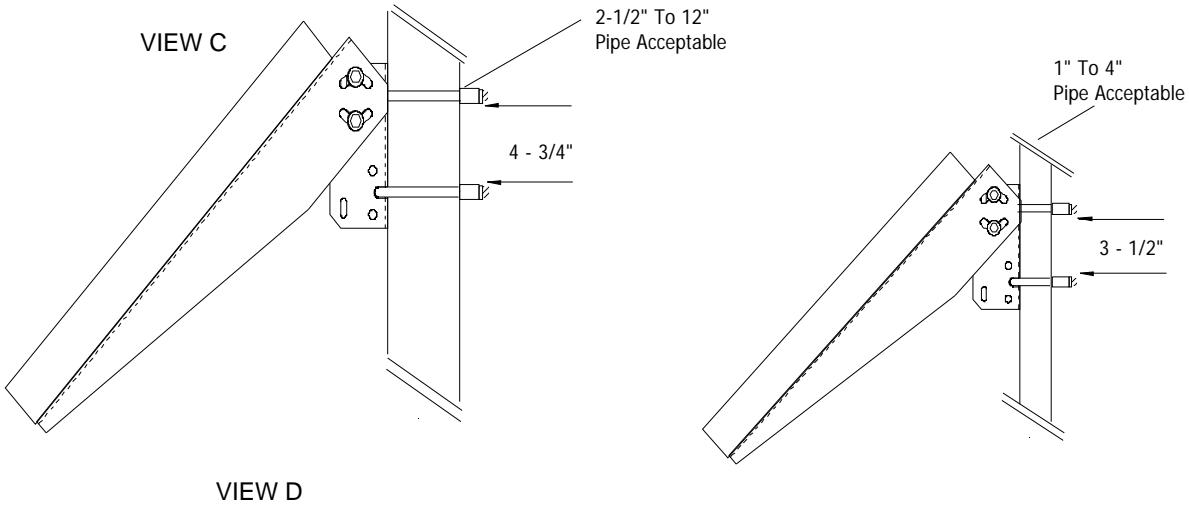

Pole Mounting Using
Hose Clamps. Long
Lag Screws Through
Base Mounting Holes
May Be Used For
Wooden Poles.

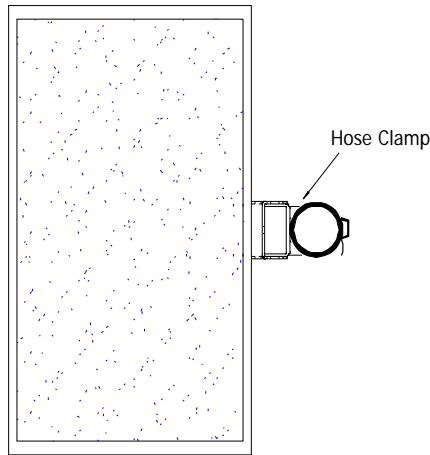

VIEW E

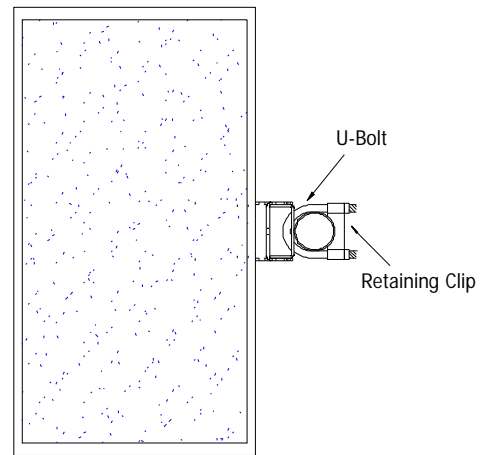

Panel Bracket Slots
Allow Rotation To
Desired Angle.

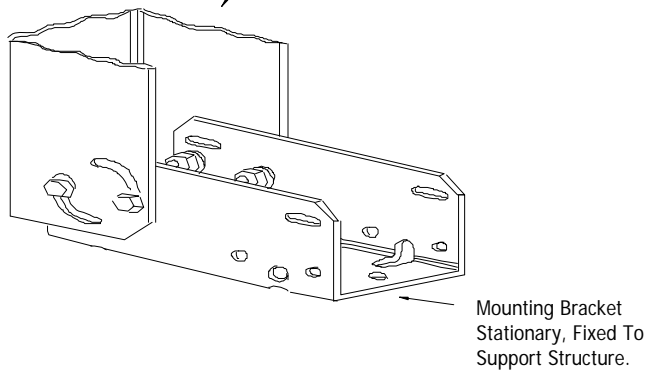

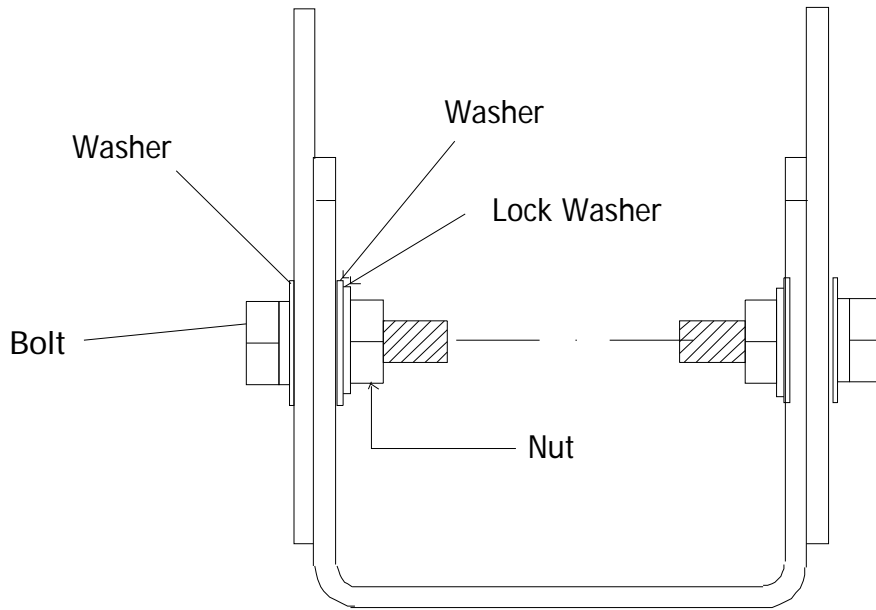
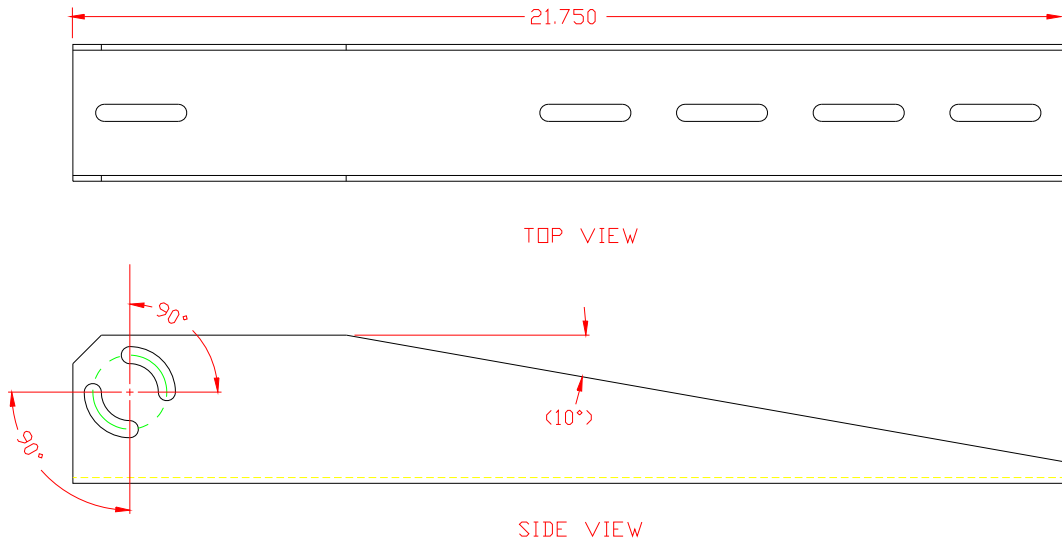



VIEW G

Mounting Options. View A illustrates the mounting hardware assembled for a flat mount to a rooftop or wall. The two-piece assembly consists of the PANEL BRACKET, which is bolted to the existing holes in the panel frame, and the MOUNTING BRACKET, which is attached by means of the PANEL BRACKET'S four bolts slots (see also View F). View B shows the same MOUNTING BRACKET assembled in an inverted configuration. View C illustrates the panel mounted to an exterior wall and a roof top. View D shows the panel mounted to a pole by hose clamps, and View E illustrates a pole mount using U-bolts.

Mounting Hardware. The PANEL BRACKET is attached to the SX-10, SX-20, SX-30, or SX-40 panel frame by two 5/16" x 3/4" bolt assemblies. The MOUNTING BRACKET is attached to the PANEL BRACKET by four 5/16" x 3/4" bolt assemblies. Bolt assemblies include flat washer(s), split lock washer, and nut.

Proper assembly sequence is illustrated in View G. All the above hardware is included in the Single Panel Mounting Hardware Kit.

When mounting to a flat surface, bolts or lag screws (for wood) should be used. In addition to the two 13/32" bolt holes in the MOUNTING BRACKET base, the four U-slots (called out in View B) may also be used as additional fastening points for bolts or screws (use 5/16" or 3/8" diameter fasteners with flat washers under the heads).

Pole mounting can be accomplished with hose clamps (View D) or U-bolts with retaining clamps (View E). Appropriate size hole clamps or U-bolts are widely available from hardware or automotive parts stores, or may be separately ordered from Ameresco Solar (include pole, diameter with order information).