

ENVELOPE / ASSEMBLY DRAWING

008974

SPECIFICATION CONTROL DRAWING THIS DRAWING CONTAINS INFORMATION PROPRIETARY TO RF INDUSTRIES, LTD. ANY UNAUTHORIZED USE OF THIS DRAWING IS EXPRESSLY PROHIBITED. ANY VIOLATION IS PUNISHABLE UNDER U.S. COPYRIGHT LAWS.	REV	DESCRIPTION	DWN	DATE	APPROVED
	A	ENGINEERING RELEASE	WMD	11/11/93	C. JONES
	B	CHG PART # FROM RSA-2373 TO RSA-3271	WMD	1/3/94	C. JONES
	C	CHANGE TERMINATION TO SOLDER POT	KMM	9/7/96	R. RICE

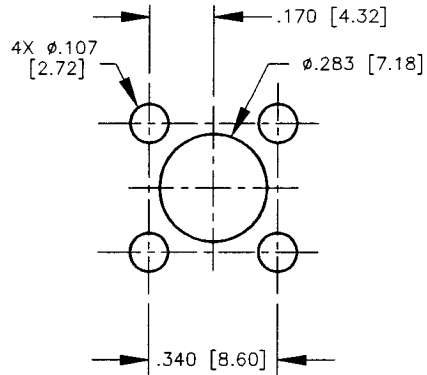

SUGGESTED MOUNTING CONFIGURATION

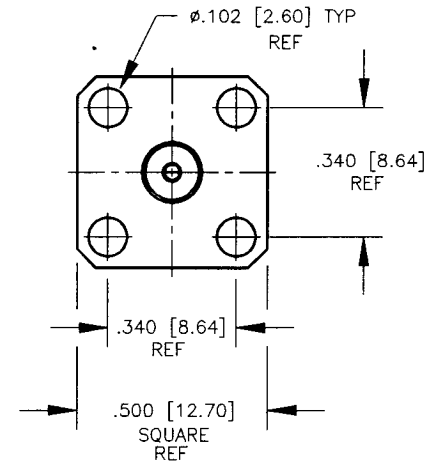
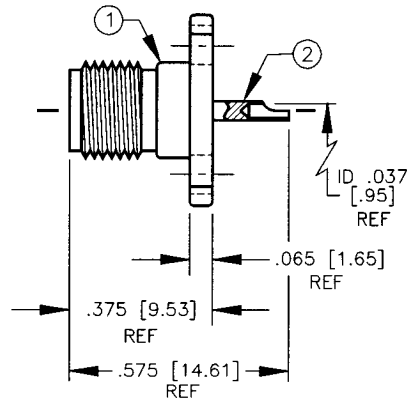

SPECIFICATIONS:

IMPEDANCE: 50 OHMS
 WORKING VOLTAGE: 335 VRMS @ SEA LEVEL
 FREQUENCY RANGE: 0--12.4 GHz

DIMENSIONS ARE IN INCHES AND [MILLIMETERS]

UNLESS OTHERWISE NOTED TOLERANCES ARE:

DECIMALS DIAMETER

RF connectors
 DIVISION OF RF INDUSTRIES, LTD.

7610 MIRAMAR RD
 SAN DIEGO, CA 92126
 (619)549-6340
 (619)549-6345 FAX

RSA-3271

SMA FEMALE 4 HOLE FLANGE PANEL MOUNT, SOLDER

5	RETAINING RING	1	BRASS	NICKEL
4	DIELECTRIC	1	TEFLON	NONE
3	DIELECTRIC	1	TEFLON	NONE
2	PIN	1	BeCu	GOLD
1	BODY	1	BRASS	NICKEL
ITEM	DESCRIPTION	QTY	MATERIAL	FINISH

DRAWN	K. MAXWELL	9/7/96
CHECKED	<i>R. Rice</i>	9/10/96
ORL DRAWN	K. MAXWELL	11/11/93
APPROVALS	DATE	

SIZE	CABLE GROUP	DWG NO.	REV
A	N/A	8250	C
SCALE:	2:1	CAD FILE	13ARC B
			SHEET 1 OF 1