

## 802.11n/ac 6-Lead Patch Antenna With RPSMA Plug Connectors

TerraWave's new line of 802.11n/ac antennas are designed to operate with any manufacturer's enterprise-class 802.11n and 802.11ac access points (APs). This 2.4/5 GHz 6 dBi 6-lead patch antenna comes with six RPSMA Plug connectors and 36" cables. With dual-band leads, each cable supports both 2.4 and 5 GHz, making it an ideal and aesthetically pleasing antenna to support demanding outdoor applications in 802.11n and 802.11ac wireless communication systems. The antenna radome is designed to withstand challenging environments where there is exposure to moisture and dust and comes with an articulating mount. *All TerraWave antennas are covered by the company's two-year TerraNet warranty program. For questions or to purchase product, contact your Regional Sales Executive at 210-375-8482, 800-851-4965 or sales@terrawave.com.*

Specifications	
Model	M6060060P1D63620V
Frequency Range	2400 ~ 2500 / 5150 ~ 5850 MHz
Gain	6 dBi
Vertical Beamwidth	80°±20° / 45°±20°
Horizontal Beamwidth	80°±20° / 45°±20°
VSWR	≤ 2.0 / ≤ 2.5
Front-to-back ratio	≥ 18
Polarization	Vertical
Max Power	100 Watts
Connector	6 x RPSMA Plug
Pigtail Length	36" (w/ Connector)
Dimensions	9.2" x 9.0" x 1.1"
Weight	3.7 lbs
Operating Temperature Range	-40°F to +140°F
Rated Wind Velocity	134.2 mph
Mount Style	Wall or Mast/Pole

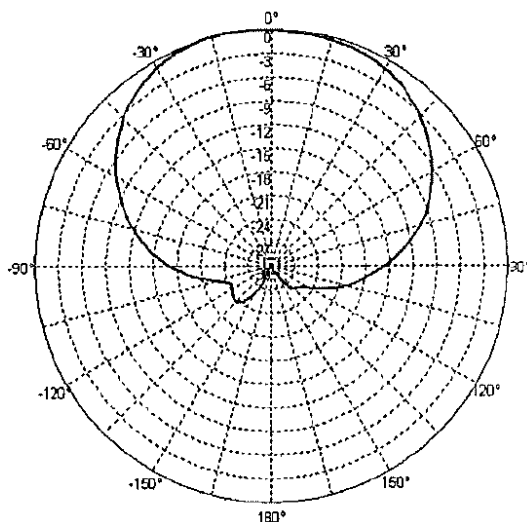

2.4 GHz

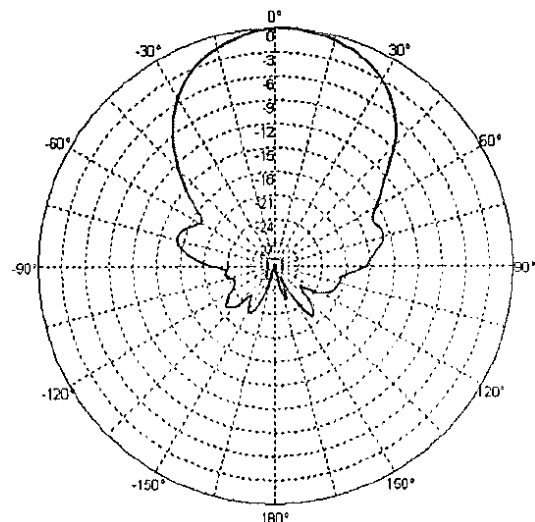

5 GHz

# 802.11n/ac 6-Lead Patch Antenna With RPSMA Plug Connectors

Wall Mount with screws:

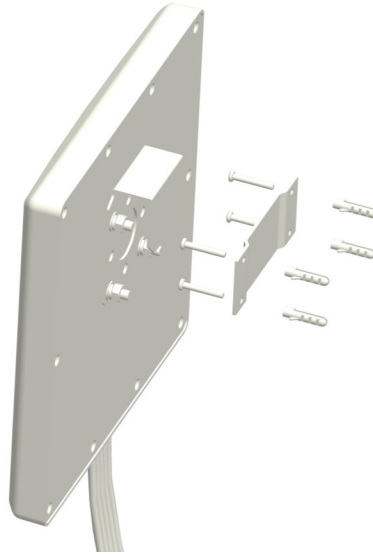

Mast Mount with Articulating Mount:  
*Note: Articulating Mount can also be Wall Mounted*

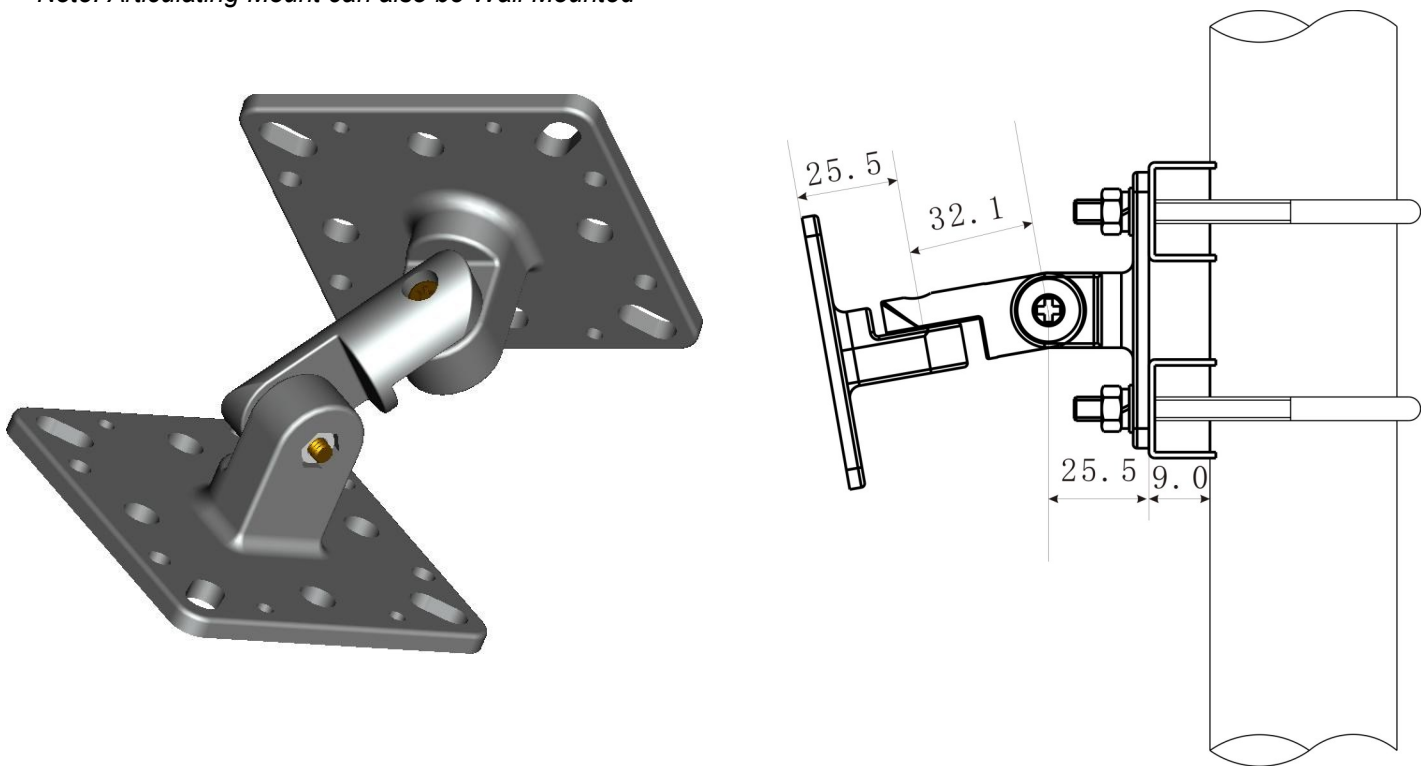

# 802.11n/ac 6-Lead Patch Antenna With RPSMA Plug Connectors

