

SHPD6-6.4

1.8 m | 6 ft Super High Performance
Parabolic Reflector Antenna, Dual-polarized,
6.425-7.125GHz



General Specifications

Antenna Type	Super High Performance Parabolic Reflector Antenna
Size, nominal	6 ft 1.8 m
Polarization	Dual

Electrical Specifications

Operating Frequency Band	6.425 - 7.125 GHz
Half Power Beamwidth, Horizontal	1.9 degrees
Half Power Beamwidth, Vertical	1.9 degrees
Cross-Polarization Discrimination	30 dB
Front to Back Ratio (F/B)	72 dB
Gain, Low Frequency	38.7 dBi
Gain, Md Frequency	38.9 dBi
Gain, High Frequency	39.2 dBi
VSWR	1.30:1
Return Loss	-17.1 dB

Mechanical Specifications

Fine Azimuth Adjustment	+/- 10 degrees
-------------------------	----------------

Fine Elevation Adjustment	+/- 10 degrees
Mounting Pipe Diameter, Min	4.5 inch 11.4 cm
Mounting Pipe Diameter, Max	4.5 inch 11.4 cm
Net Weight	251 lbs 113 kg
Wind Velocity Operational	90 mph 145 km/h
Wind Velocity Survival Rating	125 mph 201 km/h
Mechanical Configuration	SHP6
Axial Force (FA)	1680 lbs 7473 N
Side Force (FS)	832 lbs 3700 N
Twisting Moment (MT)	2100 ft-lbs 2847 Nm
Operating temperature range	-40 to +60 C
Max pressure, psig, (if waveguide interface)	5

Regulatory Compliance

FCC	Part 101 Cat. A
ETSI	302217 R1 C3
RoHS-complaint	Yes

Shipping Information

Package Type	Wood Crate
Gross Weight	403 lbs 182.8 kg
Dimensions, L x W x H	77 x 35 x 80in 195 x 89 x 203 cm
Shipping Volume	124.77 cu ft 3.53 cu m

Additional Comments

Choose Radiowaves products for best performance and reliability

Technical Drawings

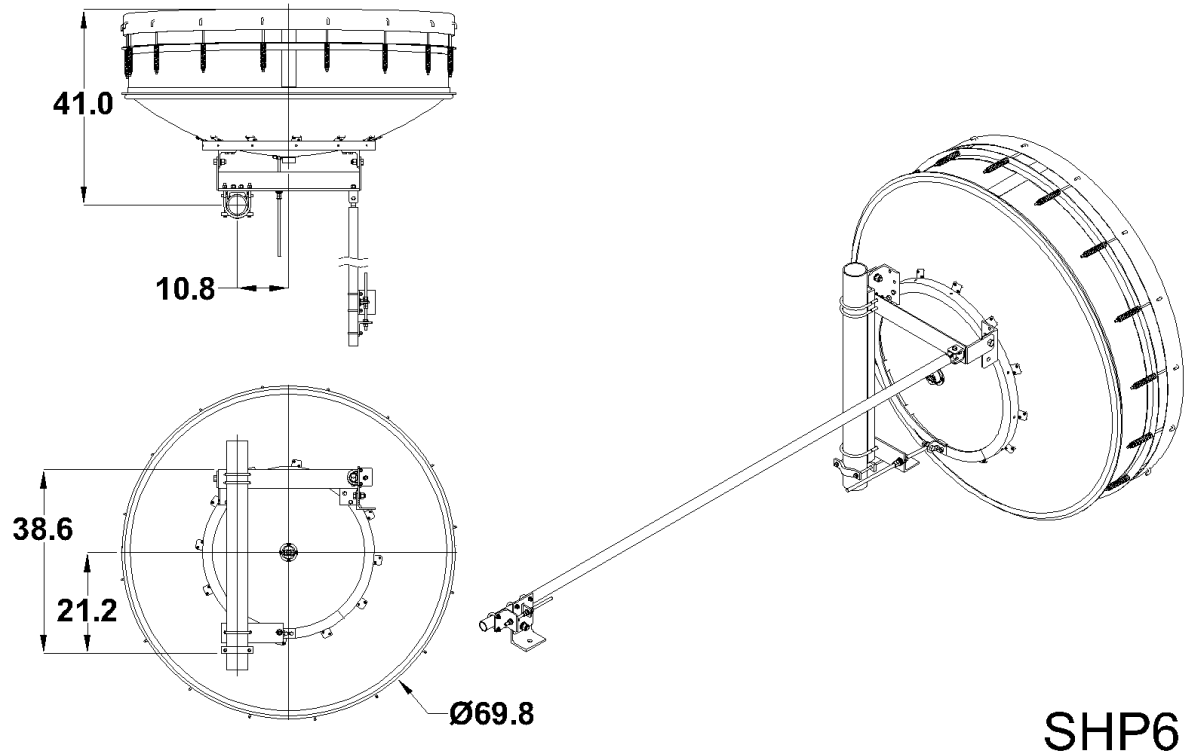

Radiowaves Glossary

Axial Force:	Force applied to the face of the antenna due to wind at specified wind speed
Beamwidth	The total width of the main beam measured in degrees between the 3-dB (half-power) points on either side of the peak of the main beam
Cross Polarization Discrimination (XPD)	The dB difference between maximum received co-polarized signal at electrical boresight and maximum received cross-polarized signal
Front to Back Ratio (F/B)	The dB difference between maximum received signal at electrical boresight to maximum received signal behind the antenna (180 +/- 40 degrees)
Gain	A measure of how well the antenna focuses available energy into a single beam. Larger antennas typically have higher gains and smaller beamwidths.
Gross Weight	Shipping weight, includes weight of antenna plus packaging materials
Net Weight	Weight of antenna only as mounted on tower.
Operating Frequency Band	The frequency limits between which the antenna meets declared specifications. Antennas may operate outside the frequency band with mild performance degradation.
Return Loss	A measure of how much rf energy incident upon the antenna is reflected back from whence it came, expressed as a negative dB value.
Side Force (FS)	Force applied to the side of the antenna due to wind at specified wind speed
Twisting Moment (MT)	The torsional (twisting) moment (force x distance) applied to the mounting pipe due to wind at the specified wind speed.

VSWR

A measure of how much rf energy incident upon the antenna is reflected back from whence it came, expressed as a ratio

Wind Velocity Operational

Wind speed where the antenna deflection is less than or equal to 0.1 degrees

Wind Velocity Survival Rating

Wind speed where the antenna will not suffer permanent damage, but may require re-pointing.