

Solar Applications I2R SPV100 3-40

Part# 1104-11-105



DIN rail mounted DC surge protection device, designed with MOV technology to meet Type 2 requirements. Equipped with suppression status visual indication and electrically isolated "Form C" dry contacts to allow remote monitoring.

Main Technical Data

Electrical Performance	
Tested To	IEC 61643-1
Arrester Class	Class II, Type 2
Number Of Ports	Single port device
Technology	MOV
Nominal Operating Voltage U_n	100 Vdc
Maximum Continuous Operating Voltage U_c	130 Vdc
Nominal Discharge Current I_n (8x20 μ s)	20 kA
Maximum Discharge Current I_{max} (8x20 μ s) Type 2	40 kA
Voltage Protection Level U_p	1.2 kV
Response Time	< 25 ns
Recommended Over-Current Protection Device	32 A circuit breaker with C tripping characteristic (per IEC 60364-4-43)
Status Indication	Visual indication LED: Black = normal, Red = replace Contact switch for remote annunciation
Maximum Contact Switch Rating	250 Vac / 3 A
Mechanical	
Location Category	Indoor only
Method Of Mounting	Fixed 35mm DIN rail
Dimension (H X W X D)	90 mm x 54 mm x 68 mm (3.6" x 2.2" x 2.7")
Weight (Max)	0.33 kg (0.74 lb)
Maximum Wire Size	25 mm ² (#4 AWG)
Stripping Length Terminals	10 mm (0.375")
Torque Terminals	4.5 Nm (3.3 ft-lb)
Maximum Wire Size Contacts	1.5 mm ² (#16 AWG)
Stripping Length Contacts	7 mm (0.25")
Torque Contacts	1 Nm (0.75 ft-lb)
Environmental	
Operating Temperature	-40°C to +70°C
Relative Humidity	≤ 95% non condensing
Enclosure Protection Level	IP20
Housing Inflammability Rating	PA66, UL94 V-0
Certifications	RoHS compliant

Product Specification

Schematic

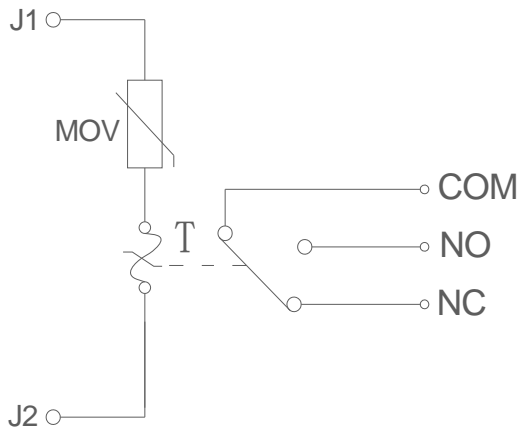

Structure

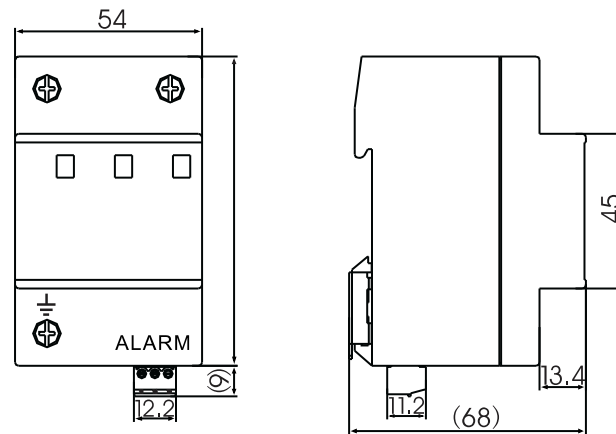

Wiring Diagram

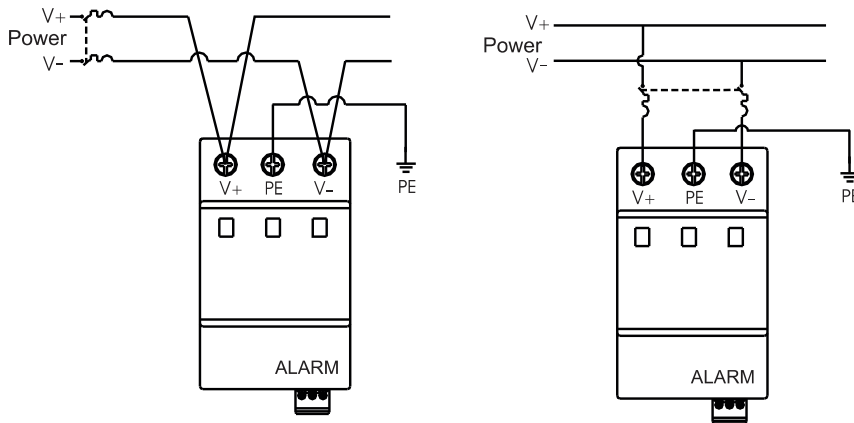

Installation and Wiring

1. Install only in a restricted access enclosure or control cabinet that requires a key or tool to open.
2. This SPD should only be installed and serviced by qualified electrical personnel.
3. All National and Local Electric Codes must be observed.
4. Confirm that the SPD is rated for the voltage of the application.
5. Before installation, turn off all power to equipment to prevent accidental electrical shock or injury.
6. Replace all covers and doors before restoring power to this equipment.
7. Kelvin or 'V' connections are recommended, keeping all wires as short as possible (less than 0.5 m) and free of sharp bends.
8. Over-current protection device should be used on the power supply side of SPD. Reference IEC 60364-4-43.
9. The ground conductor should be insulated stranded copper greater than 10 mm² (#8 AWG) diameter. The power conductors should be insulated stranded copper greater than 6 mm² (#10 AWG) diameter. If Kelvin connections are used, the load capacity of the conductor must be sized according to the load. Reference IEC 60364-5-532.

Usage and Maintenance

1. The SPD should be scheduled for periodic inspection to ensure SPD is operational and all wire connections are tight.
2. If SPD is damaged, contact Transtector for replacement at +1.208.772.8515 or 1.800.882.9110, or online at www.transtector.com.