

L1TDF-PL

7-16 DIN Female Positive Lock for 1/4 in LDF1-50 cable



General Specifications

Interface	7-16 DIN Female
Body Style	Straight
Brand	HELIAX®
Mounting Angle	Straight

Electrical Specifications

Connector Impedance	50 ohm
Operating Frequency Band	0 – 6000 MHz
Cable Impedance	50 ohm
3rd Order IMD, typical	-107 dBm @ 910 MHz
3rd Order IMD Test Method	Two +43 dBm carriers
RF Operating Voltage, maximum (vrms)	778.00 V
dc Test Voltage	2200 V
Outer Contact Resistance, maximum	1.50 mOhm
Inner Contact Resistance, maximum	0.40 mOhm
Insulation Resistance, minimum	10000 MOhm
Average Power	0.6 kW @ 900 MHz
Peak Power, maximum	12.10 kW
Insertion Loss, typical	0.05 dB
Shielding Effectiveness	-110 dB

Outline Drawing

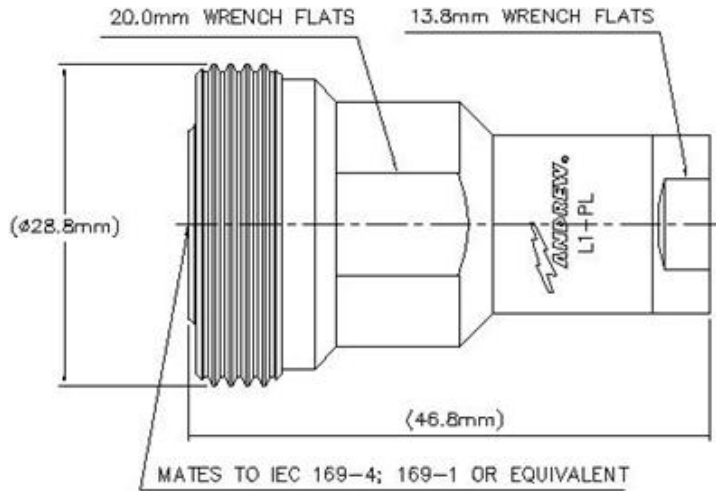

Mechanical Specifications

Outer Contact Attachment Method	Self-flare
Inner Contact Attachment Method	Captivated
Outer Contact Plating	Trimetal
Inner Contact Plating	Silver
Attachment Durability	25 cycles
Interface Durability	500 cycles
Interface Durability Method	IEC 61169-4:17
Connector Retention Tensile Force	450 N 101 lbf
Connector Retention Torque	1.40 N-m 1.03 ft lb
Insertion Force	200.00 N 44.96 lbf
Insertion Force Method	IEC 61169-1:15.2.4
Pressurizable	No
Coupling Nut Proof Torque	35.00 N-m 25.81 ft lb

Dimensions

Nominal Size	1/4 in
Diameter	28.84 mm 1.14 in
Height	28.84 mm 1.14 in
Length	46.76 mm 1.84 in
Weight	87.02 g 0.19 lb
Width	28.84 mm 1.14 in

Environmental Specifications

L1TDF-PL



Operating Temperature	-55 °C to +85 °C (-67 °F to +185 °F)
Storage Temperature	-65 °C to +125 °C (-85 °F to +257 °F)
Immersion Depth	1 m
Immersion Test Mating	Mated
Immersion Test Method	IEC 60529:2001, IP68
Moisture Resistance Test Method	IEC 60068-2-3
Mechanical Shock Test Method	IEC 60068-2-27
Thermal Shock Test Method	IEC 60068-2-14
Vibration Test Method	IEC 60068-2-6
Corrosion Test Method	IEC 60068-2-11

Standard Conditions

Attenuation, Ambient Temperature	20 °C 68 °F
Average Power, Ambient Temperature	40 °C 104 °F
Average Power, Inner Conductor Temperature	100 °C 212 °F

Return Loss/VSWR

Frequency Band	VSWR	Return Loss (dB)
824–2200 MHz	1.04	34.00
2200–2700 MHz	1.04	34.00
3000–4000 MHz	1.04	35.00
4000–6000 MHz	1.17	22.00

Regulatory Compliance/Certifications

Agency	Classification
RoHS 2011/65/EU	Compliant by Exemption
China RoHS SJ/T 11364-2006	Above Maximum Concentration Value (MCV)
ISO 9001:2008	Designed, manufactured and/or distributed under this quality management system



* Footnotes

Immersion Depth	Immersion at specified depth for 24 hours
Insertion Loss, typical	$0.05\sqrt{\text{freq}}$ (GHz) (not applicable for elliptical waveguide)