

# TA-DMDM

---

## 7-16 DIN Male to 7-16 DIN Male Low-PIM Adapter

### Product Classification

**Product Type** Adapter

### General Specifications

**Body Style** Straight

**Inner Contact Plating** Silver

**Interface** 7-16 DIN Male

**Interface 2** 7-16 DIN Male

**Mounting Angle** Straight

**Outer Contact Plating** Trimetal

**Pressurizable** No

### Dimensions

**Width** 31.75 mm | 1.25 in

**Length** 43.8 mm | 1.724 in

**Diameter** 35.92 mm | 1.414 in

### Outline Drawing

# TA-DMDM

---

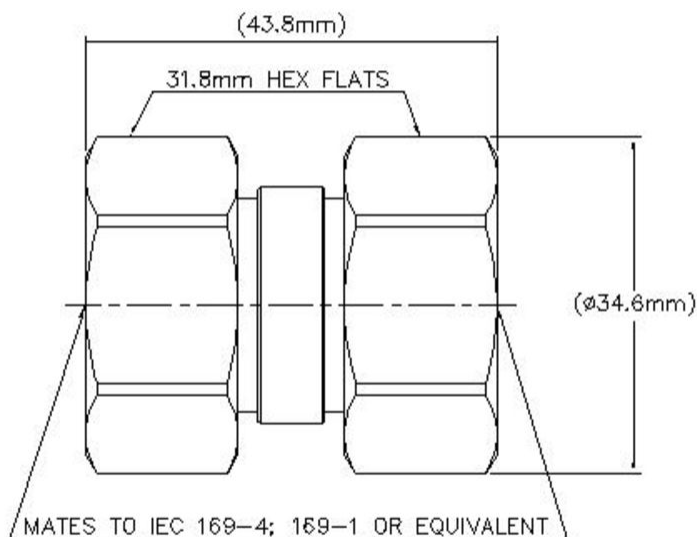

## Electrical Specifications

<b>3rd Order IMD at Frequency</b>	-163 dBc @ 1800 MHz
<b>3rd Order IMD Test Method</b>	Two +43 dBm carriers
<b>Average Power at Frequency</b>	1,300.0 W @ 900 MHz
<b>Connector Impedance</b>	50 ohm
<b>dc Test Voltage</b>	4000 V
<b>Inner Contact Resistance, maximum</b>	0.4 mOhm
<b>Insulation Resistance, minimum</b>	10000 MOhm
<b>Operating Frequency Band</b>	0 – 6000 MHz
<b>Outer Contact Resistance, maximum</b>	1.5 mOhm
<b>Peak Power, maximum</b>	28.8 kW
<b>RF Operating Voltage, maximum (vrms)</b>	1200 V

# TA-DMDM

---

## VSWR/Return Loss

Frequency Band	VSWR	Return Loss (dB)
0–3000 MHz	1.04	36
3000–6000 MHz	1.14	24

## Mechanical Specifications

<b>Coupling Nut Proof Torque</b>	50 N-m   442.537 in lb
<b>Coupling Nut Proof Torque Method</b>	IEC 61169-4:9.3.6
<b>Coupling Nut Retention Force</b>	800 N   179.847 lbf
<b>Coupling Nut Retention Force Method</b>	IEC 61169-16:9.3.11
<b>Insertion Force</b>	200 N   44.962 lbf
<b>Insertion Force Method</b>	IEC 61169-4:15.2.4
<b>Interface Durability</b>	500 cycles
<b>Interface Durability Method</b>	IEC 61169-4:9.5
<b>Mechanical Shock Test Method</b>	IEC 60068-2-27

## Environmental Specifications

<b>Operating Temperature</b>	-55 °C to +85 °C (-67 °F to +185 °F)
<b>Storage Temperature</b>	-65 °C to +125 °C (-85 °F to +257 °F)
<b>Average Power, Ambient Temperature</b>	40 °C   104 °F
<b>Average Power, Inner Conductor Temperature</b>	100 °C   212 °F
<b>Climatic Sequence Test Method</b>	IEC 60068-1
<b>Corrosion Test Method</b>	IEC 60068-2-11
<b>Damp Heat Steady State Test Method</b>	IEC 60068-2-3
<b>Thermal Shock Test Method</b>	IEC 60068-2-14
<b>Vibration Test Method</b>	IEC 60068-2-6

## Packaging and Weights

<b>Weight, net</b>	118.43 g   0.261 lb
--------------------	---------------------

## Regulatory Compliance/Certifications

Agency	Classification
CHINA-ROHS	Below maximum concentration value

# TA-DMDM

---

ISO 9001:2015

Designed, manufactured and/or distributed under this quality management system

REACH-SVHC

Compliant as per SVHC revision on [www.commscope.com/ProductCompliance](http://www.commscope.com/ProductCompliance)

ROHS

Compliant

