

# 240PTF-C

---

TNC Female for CNT-240 braided cable

## Product Classification

<b>Product Type</b>	Braided cable connector
<b>Product Brand</b>	CNT®

## General Specifications

<b>Body Style</b>	Straight
<b>Inner Contact Attachment Method</b>	Captivated
<b>Inner Contact Plating</b>	Gold
<b>Interface</b>	TNC Female
<b>Outer Contact Attachment Method</b>	Clamp
<b>Outer Contact Plating</b>	Trimetal
<b>Pressurizable</b>	No

## Dimensions

<b>Width</b>	12.6 mm   0.496 in
<b>Length</b>	34.36 mm   1.353 in
<b>Diameter</b>	12.6 mm   0.496 in
<b>Nominal Size</b>	0.240 in

## Outline Drawing

# 240PTF-C

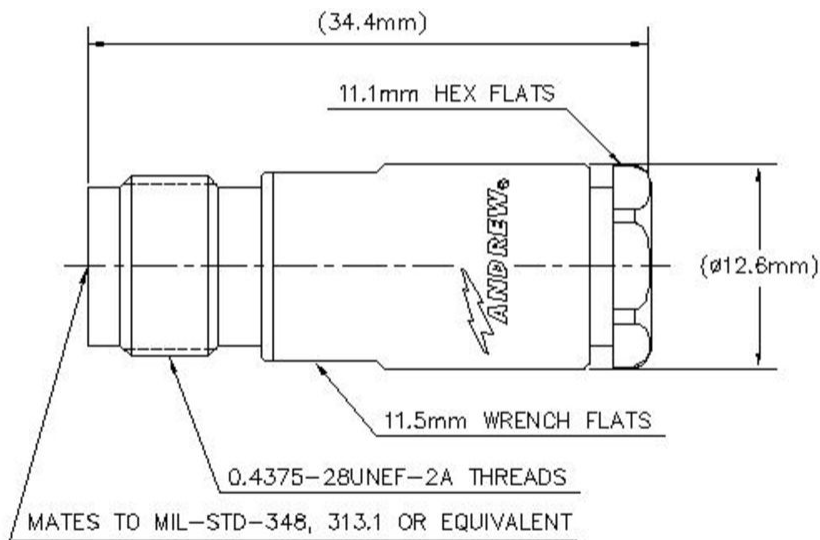

## Electrical Specifications

<b>Insertion Loss, typical</b>	0.05 dB
<b>Average Power at Frequency</b>	260.0 W @ 900 MHz
<b>Cable Impedance</b>	50 ohm
<b>Connector Impedance</b>	50 ohm
<b>dc Test Voltage</b>	1500 V
<b>Inner Contact Resistance, maximum</b>	1.5 mOhm
<b>Insulation Resistance, minimum</b>	5000 MOhm
<b>Operating Frequency Band</b>	0 – 6000 MHz
<b>Outer Contact Resistance, maximum</b>	0.4 mOhm
<b>Peak Power, maximum</b>	5 kW
<b>RF Operating Voltage, maximum (vrms)</b>	500 V

# 240PTF-C

---

## VSWR/Return Loss

Frequency Band	VSWR	Return Loss (dB)
0–3000 MHz	1.05	32.3
3000–6000 MHz	1.22	20.1

## Mechanical Specifications

Connector Retention Tensile Force	134 N   30.124 lbf
Connector Retention Torque	0.23 N-m   2.036 in lb
Insertion Force	15 N   3.372 lbf
Insertion Force Method	IEC 61169-17:9.3.5
Interface Durability	500 cycles
Interface Durability Method	IEC 61169-17:9.5
Mechanical Shock Test Method	IEC 60068-2-27

## Environmental Specifications

Operating Temperature	-40 °C to +85 °C (-40 °F to +185 °F)
Storage Temperature	-65 °C to +125 °C (-85 °F to +257 °F)
Average Power, Ambient Temperature	40 °C   104 °F
Average Power, Inner Conductor Temperature	100 °C   212 °F
Climatic Sequence Test Method	IEC 60068-1
Corrosion Test Method	IEC 60068-2-11
Damp Heat Steady State Test Method	IEC 60068-2-3
Immersion Depth	1 m
Immersion Test Mating	Mated
Immersion Test Method	IEC 60529:2001, IP68
Thermal Shock Test Method	IEC 60068-2-14
Vibration Test Method	IEC 60068-2-6

## Packaging and Weights

Weight, net	22.6 g   0.05 lb
-------------	------------------

## Regulatory Compliance/Certifications

Agency	Classification
--------	----------------

# 240PTF-C

---

CHINA-ROHS	Below maximum concentration value
ISO 9001:2015	Designed, manufactured and/or distributed under this quality management system
REACH-SVHC	Compliant as per SVHC revision on <a href="http://www.commscope.com/ProductCompliance">www.commscope.com/ProductCompliance</a>
ROHS	Compliant



## \* Footnotes

<b>Immersion Depth</b>	Immersion at specified depth for 24 hours
<b>Insertion Loss, typical</b>	$0.05\sqrt{\text{freq}}$ (GHz) (not applicable for elliptical waveguide)