

# CM-60D-B

---

## Chain Mount Base Kit, 16 ft chain

### Product Classification

**Product Type** Chain mount kit

### General Specifications

**Chains, quantity** 2

**Pipe, quantity** 0

**Sectors, quantity** 2

### Dimensions

**Height** 152.4 mm | 6 in

**Width** 203.2 mm | 8 in

**Chain Length** 4,902.2 mm | 193 in

**Length** 203.2 mm | 8 in

**Mounting Diameter, maximum** 1524 mm | 60 in

**Mounting Diameter, minimum** 203.2 mm | 8 in

**Pipe Outer Diameter** 60.96 mm | 2.4 in

**Mounting Circumference, maximum** 4,775.2 mm | 188 in

**Mounting Circumference, minimum** 635 mm | 25 in

# CM-60D-B

## Outline Drawing

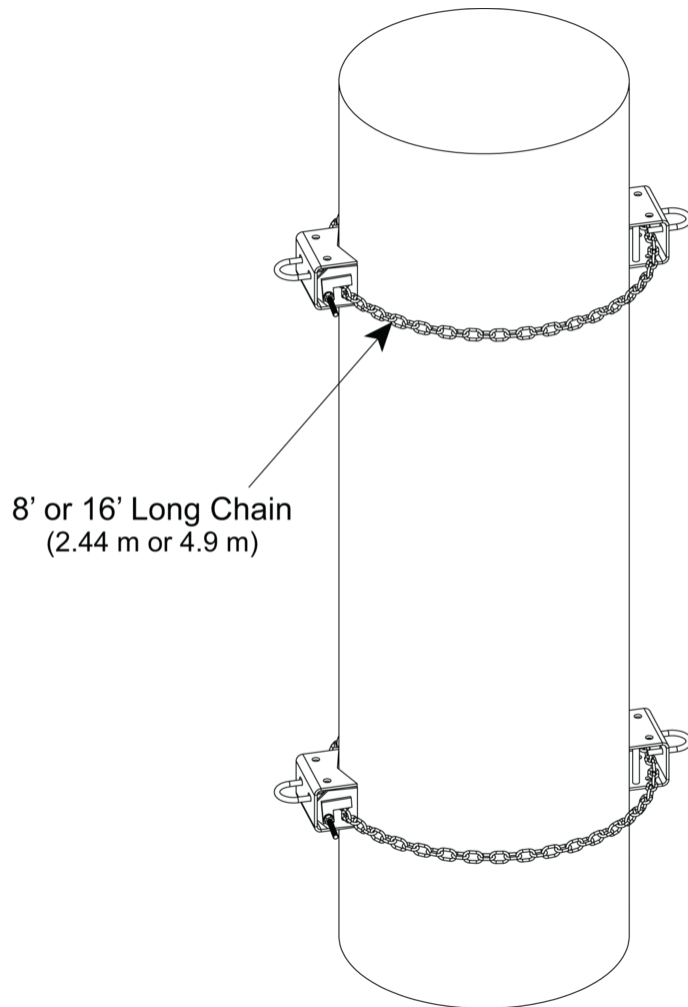

## Material Specifications

**Material Type** Hot dip galvanized steel

## Mechanical Specifications

**Wind Rating** 120 mph (BWS) at 100 ft AGL

**Wind Rating Criteria** One 96 in x 10 in panel antenna per sector

**Wind Rating Test Method** TIA/EIA-222

## Environmental Specifications

**Man Rating** 250 lb vertical man load at 15 mph (BWS)

# CM-60D-B

---

## Packaging and Weights

<b>Included</b>	Chains
<b>Packaging quantity</b>	1
<b>Weight, net</b>	23 kg   50.706 lb

## Regulatory Compliance/Certifications

<b>Agency</b>	<b>Classification</b>
ISO 9001:2015	Designed, manufactured and/or distributed under this quality management system



## \* Footnotes

<b>Man Rating</b>	BWS—w Base Wind Speed
<b>Wind Rating</b>	BWS—w Base Wind Speed; FBC—Florida Building Code