

L2TNR-PL

Type N Male Right Angle Positive Lock for 3/8 in LDF2-50 cable



Product Classification

Product Type	Wireless and radiating connector
Product Brand	HELIAX®

General Specifications

Body Style	Right angle
Cable Family	LDF2-50
Inner Contact Attachment Method	Captivated
Inner Contact Plating	Silver
Interface	N Male
Mounting Angle	Right angle
Outer Contact Attachment Method	Ring-flare
Outer Contact Plating	Trimetal
Pressurizable	No

Dimensions

Height	20.57 mm 0.81 in
Width	22.35 mm 0.88 in
Length	58.42 mm 2.3 in
Right Angle Length	20.57 mm 0.81 in
Diameter	22.35 mm 0.88 in
Nominal Size	3/8 in

Outline Drawing

L2TNR-PL

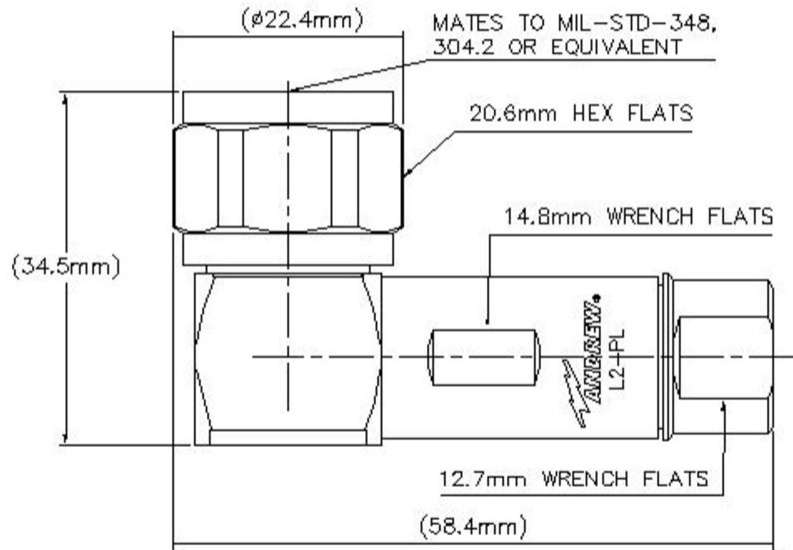

Electrical Specifications

3rd Order IMD at Frequency	-107 dBm @ 910 MHz
3rd Order IMD Test Method	Two +43 dBm carriers
Insertion Loss, typical	0.05 dB
Average Power at Frequency	0.7 kW @ 900 MHz
Cable Impedance	50 ohm
Connector Impedance	50 ohm
dc Test Voltage	2500 V
Inner Contact Resistance, maximum	1 mOhm
Insulation Resistance, minimum	5000 MOhm
Operating Frequency Band	0 – 10000 MHz
Outer Contact Resistance, maximum	0.25 mOhm

L2TNR-PL

Peak Power, maximum	10 kW
RF Operating Voltage, maximum (vrms)	707 V
Shielding Effectiveness	-110 dB

VSWR/Return Loss

Frequency Band	VSWR	Return Loss (dB)
0–960 MHz	1.06	32
960–2200 MHz	1.07	30.7
2200–2700 MHz	1.07	30
2700–4000 MHz	1.12	25.3
4000–6000 MHz	1.17	22.6
6000–8000 MHz	1.19	21.5
8000–10000 MHz	1.19	21.5

Mechanical Specifications

Attachment Durability	25 cycles
Connector Retention Tensile Force	671.68 N 151 lbf
Connector Retention Torque	2.7 N-m 23.897 in lb
Coupling Nut Proof Torque	1.7 N-m 15.046 in lb
Coupling Nut Retention Force	449.98 N 101.16 lbf
Coupling Nut Retention Force Method	MIL-C-39012C-3.25, 4.6.22
Insertion Force	27.98 N 6.29 lbf
Insertion Force Method	IEC 61169-1:15.2.4
Interface Durability	500 cycles
Interface Durability Method	IEC 61169-16:9.5
Mechanical Shock Test Method	IEC 60068-2-27

Environmental Specifications

Operating Temperature	-55 °C to +85 °C (-67 °F to +185 °F)
Storage Temperature	-65 °C to +125 °C (-85 °F to +257 °F)
Attenuation, Ambient Temperature	20 °C 68 °F
Average Power, Ambient Temperature	40 °C 104 °F
Average Power, Inner Conductor Temperature	100 °C 212 °F
Corrosion Test Method	IEC 60068-2-11

L2TNR-PL

Immersion Depth	1 m
Immersion Test Mating	Mated
Immersion Test Method	IEC 60529:2001, IP68
Moisture Resistance Test Method	IEC 60068-2-3
Thermal Shock Test Method	IEC 60068-2-14
Vibration Test Method	IEC 60068-2-6

Packaging and Weights

Weight, net 83.48 g | 0.184 lb

Regulatory Compliance/Certifications

Agency	Classification
ISO 9001:2015	Designed, manufactured and/or distributed under this quality management system



* Footnotes

Immersion Depth	Immersion at specified depth for 24 hours
Insertion Loss, typical	$0.05\sqrt{\text{freq}}$ (GHz) (not applicable for elliptical waveguide)