

# 158EZDF

---



7-16 DIN Female EZfit® for 1-5/8 in FXL-1873 and AVA7-50 cable

## Product Classification

<b>Product Type</b>	Wireless and radiating connector
<b>Product Brand</b>	EZfit®
<b>Product Series</b>	AL7-50   AVA7RK-50
<b>Ordering Note</b>	CommScope® non-standard product

## General Specifications

<b>Body Style</b>	Straight
<b>Inner Contact Attachment Method</b>	Captivated
<b>Inner Contact Plating</b>	Silver
<b>Interface</b>	7-16 DIN Female
<b>Mounting Angle</b>	Straight
<b>Outer Contact Attachment Method</b>	Clamp
<b>Outer Contact Plating</b>	Trimetal
<b>Pressurizable</b>	No

## Dimensions

<b>Length</b>	65.28 mm   2.57 in
<b>Diameter</b>	62.99 mm   2.48 in
<b>Nominal Size</b>	1-5/8 in

## Outline Drawing

# 158EZDF

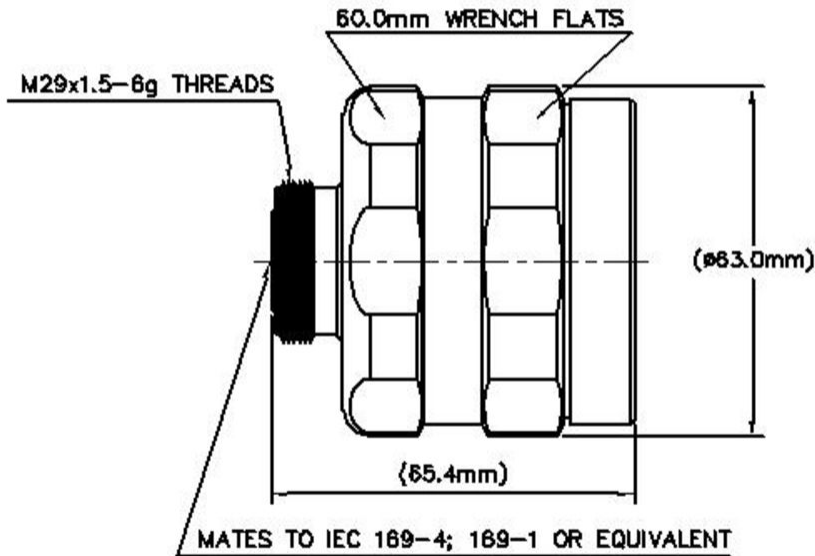

## Electrical Specifications

<b>3rd Order IMD at Frequency</b>	-116 dBm @ 1800 MHz
<b>3rd Order IMD Test Method</b>	Two +43 dBm carriers
<b>Insertion Loss, typical</b>	0.05 dB
<b>Average Power at Frequency</b>	3.0 kW @ 900 MHz
<b>Cable Impedance</b>	50 ohm
<b>Connector Impedance</b>	50 ohm
<b>dc Test Voltage</b>	4000 V
<b>Inner Contact Resistance, maximum</b>	1.5 mOhm
<b>Insulation Resistance, minimum</b>	5000 MOhm
<b>Operating Frequency Band</b>	0 – 2700 MHz
<b>Outer Contact Resistance, maximum</b>	0.8 mOhm

# 158EZDF

---

<b>Peak Power, maximum</b>	40 kW
<b>RF Operating Voltage, maximum (vrms)</b>	1415 V
<b>Shielding Effectiveness</b>	-130 dB

## VSWR/Return Loss

<b>Frequency Band</b>	<b>VSWR</b>	<b>Return Loss (dB)</b>
45–400 MHz	1.01	46.07
401–805 MHz	1.03	36.61
806–960 MHz	1.02	40.09
961–1709 MHz	1.04	34.16
1710–2170 MHz	1.04	34.7
2170–2399 MHz	1.05	32.7
2400–2700 MHz	1.06	30.72

## Mechanical Specifications

<b>Attachment Durability</b>	25 cycles
<b>Connector Retention Tensile Force</b>	2,224.11 N   500 lbf
<b>Connector Retention Torque</b>	13.56 N-m   119.998 in lb
<b>Insertion Force</b>	200.17 N   45 lbf
<b>Insertion Force Method</b>	IEC 61169-1:15.2.4
<b>Interface Durability</b>	50 cycles
<b>Interface Durability Method</b>	IEC 61169-4:9.5
<b>Mechanical Shock Test Method</b>	IEC 60068-2-27

## Environmental Specifications

<b>Operating Temperature</b>	-40 °C to +85 °C (-40 °F to +185 °F)
<b>Storage Temperature</b>	-55 °C to +85 °C (-67 °F to +185 °F)
<b>Attenuation, Ambient Temperature</b>	20 °C   68 °F
<b>Average Power, Ambient Temperature</b>	40 °C   104 °F
<b>Corrosion Test Method</b>	IEC 60068-2-11, Test Condition Ka
<b>Immersion Depth</b>	1 m
<b>Immersion Test Mating</b>	Mated
<b>Immersion Test Method</b>	IEC 60529:2001, IP68
<b>Moisture Resistance Test Method</b>	IEC 60529, IP68

# 158EZDF

---

<b>Vibration Test Method</b>	IEC 60068-2-6
<b>Water Jetting Test Mating</b>	Mated
<b>Water Jetting Test Method</b>	IEC 60529:2001, IP66

## Packaging and Weights

<b>Weight, net</b>	536.2 g   1.182 lb
--------------------	--------------------

## Regulatory Compliance/Certifications

<b>Agency</b>	<b>Classification</b>
CHINA-ROHS	Below maximum concentration value
ISO 9001:2015	Designed, manufactured and/or distributed under this quality management system
REACH-SVHC	Compliant as per SVHC revision on <a href="http://www.commscope.com/ProductCompliance">www.commscope.com/ProductCompliance</a>
ROHS	Compliant



## \* Footnotes

<b>Immersion Depth</b>	Immersion at specified depth for 24 hours
<b>Insertion Loss, typical</b>	$0.05\sqrt{\text{freq}}$ (GHz) (not applicable for elliptical waveguide)