

F1PNF-BHC

Type N Female Bulkhead for 1/4 in FSJ1-50A cable

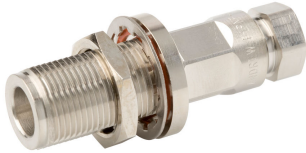

Product Classification

Product Type	Wireless and radiating connector
Product Brand	HELIAX®

General Specifications

Body Style	Bulkhead
Cable Family	FSJ1-50A
Inner Contact Plating	Silver
Interface	N Female
Mounting Angle	Straight
Outer Contact Plating	Trimetal
Pressurizable	No

Dimensions

Height	22.1 mm 0.87 in
Width	22.1 mm 0.87 in
Length	51.05 mm 2.01 in
Diameter	22.1 mm 0.87 in
Nominal Size	1/4 in

Outline Drawing

F1PNF-BHC

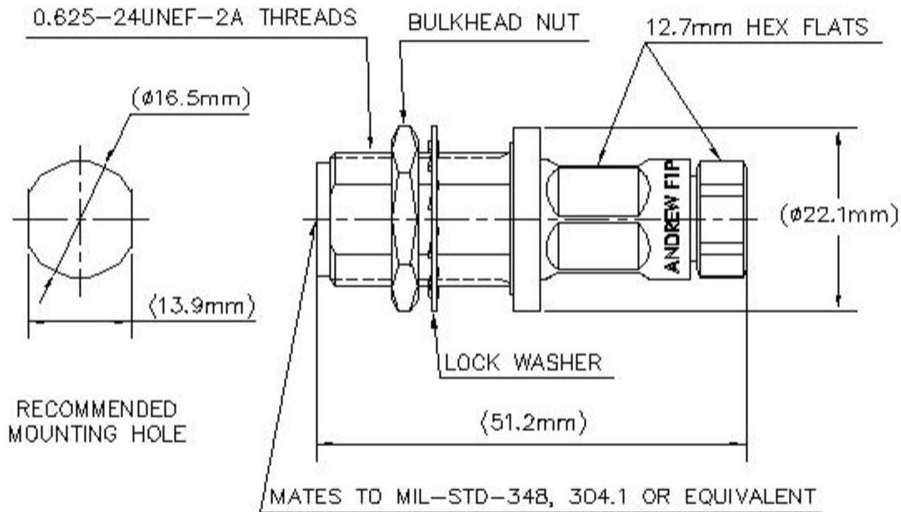

Electrical Specifications

3rd Order IMD at Frequency	-112 dBm @ 910 MHz
3rd Order IMD Test Method	Two +43 dBm carriers
Average Power at Frequency	0.4 kW @ 900 MHz
Cable Impedance	50 ohm
Connector Impedance	50 ohm
dc Test Voltage	1600 V
Inner Contact Resistance, maximum	1 mOhm
Insulation Resistance, minimum	5000 MOhm
Operating Frequency Band	0 – 6000 MHz
Outer Contact Resistance, maximum	0.25 mOhm
Peak Power, maximum	6.4 kW

F1PNF-BHC

RF Operating Voltage, maximum (vrms)	565 V
Shielding Effectiveness	-110 dB

VSWR/Return Loss

Frequency Band	VSWR	Return Loss (dB)
824–2700 MHz	1.05	34
3000–6000 MHz	1.26	19

Mechanical Specifications

Connector Retention Tensile Force	449.27 N 101 lbf
Coupling Nut Proof Torque	1.7 N-m 15.046 in lb
Coupling Nut Proof Torque Method	IEC 61169-16:9.3.11
Coupling Nut Retention Force	445 N 100.04 lbf
Coupling Nut Retention Force Method	IEC 61169-16:9.3.11
Insertion Force	124.55 N 28 lbf
Insertion Force Method	IEC 61169-16:9.3.5
Interface Durability	500 cycles
Interface Durability Method	IEC 61169-4:17
Mechanical Shock Test Method	IEC 60068-2-27

Environmental Specifications

Operating Temperature	-55 °C to +85 °C (-67 °F to +185 °F)
Storage Temperature	-65 °C to +125 °C (-85 °F to +257 °F)
Attenuation, Ambient Temperature	20 °C 68 °F
Average Power, Ambient Temperature	40 °C 104 °F
Average Power, Inner Conductor Temperature	100 °C 212 °F
Corrosion Test Method	IEC 60068-2-11
Moisture Resistance Test Method	IEC 60068-2-3
Thermal Shock Test Method	IEC 60068-2-14
Vibration Test Method	IEC 60068-2-6

Packaging and Weights

Weight, net	59.2 g 0.131 lb
--------------------	-------------------

F1PNF-BHC

Regulatory Compliance/Certifications

Agency

ISO 9001:2015

REACH-SVHC

ROHS

Classification

Designed, manufactured and/or distributed under this quality management system

Compliant as per SVHC revision on www.commscope.com/ProductCompliance

Compliant

