

CTX192126T-DS-43 | E14F60P09



Twin Triplexer, PCS/AWS/WCS-BRS, DC Sense

- BTS-to-feeder and feeder-to-antenna application
- Automatic dc switching with dc sense
- DC Load Sense in Feeder-to-Antenna applications
- Convertible mounting brackets
- New 4.3-10 connectors for improved PIM performance and size reduction

Product Classification

Product Type Triplexer

General Specifications

Color Gray

Common Port Label COMMON

Mounting Pole | Wall

Mounting Pipe Hardware Band clamps (2)

RF Connector Interface 4.3-10 Female

RF Connector Interface Body Style Long neck

Dimensions

Height 147 mm | 5.787 in

Width 177 mm | 6.969 in

Depth 105 mm | 4.134 in

Ground Screw Diameter 6 mm | 0.236 in

Mounting Pipe Diameter Range 40–160 mm

Outline Drawing

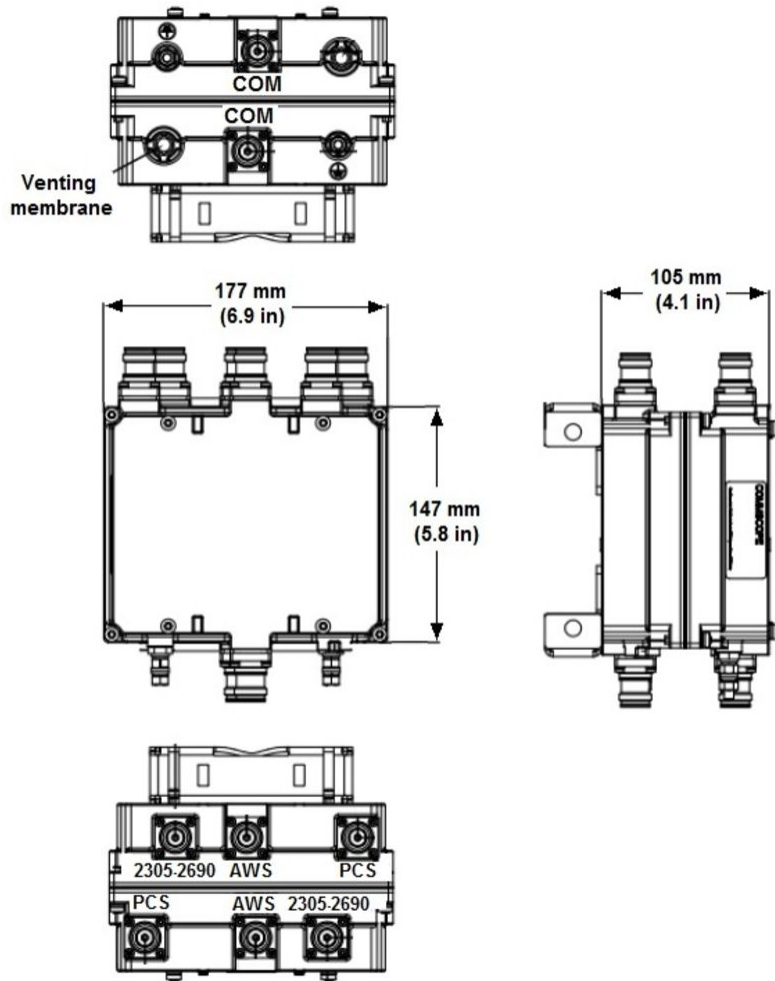

Electrical Specifications

Impedance	50 ohm
License Band, Band Pass	AWS 1700 PCS 1900 TDD 1900 TDD 2000 WCS 2300

Electrical Specifications, dc Power/Alarm

dc/AISG Pass-through Method	Auto sensing
dc/AISG Pass-through Path	See logic table
Lightning Surge Current	10 kA
Lightning Surge Current Waveform	8/20 waveform
Operating Current at Voltage	10 mA @ 12 Vdc
Voltage	7–30 Vdc

CTX192126T-DS-43 | E14F60P09

Electrical Specifications, AISG

AISG Carrier	2176 KHz \pm 100 ppm
Insertion Loss, maximum	1 dB
Return Loss, minimum	15 dB

Electrical Specifications

Sub-module	1	1	1
Branch	1	2	3
Port Designation	1695-1780 & 2110-2200	1850-1995	2305-2690
License Band	AWS 1700, Band Pass	PCS 1900, Band Pass	WCS 2300, Band Pass

Electrical Specifications, Band Pass

Frequency Range, MHz	1695-1780 2110-2200	1850-1995	2305-2690
Insertion Loss, typical, dB	0.3	0.3	0.3
Total Group Delay, maximum, ns	25	20	25
Total Group Delay, typical, ns	19	18	12
Return Loss, typical, dB	23	23	23
Isolation, typical, dB	53	53	53
Input Power, RMS, maximum, W	200	200	200
Input Power, PEP, maximum, W	2000	2000	2000
3rd Order PIM, typical, dBc	-161	-161	
3rd Order PIM Test Method	2 x 20 W CW tones	2 x 20 W CW tones	
Higher Order PIM, typical, dBc			-161
Higher Order PIM Test Method			2 x 20 W CW tones

Block Diagram

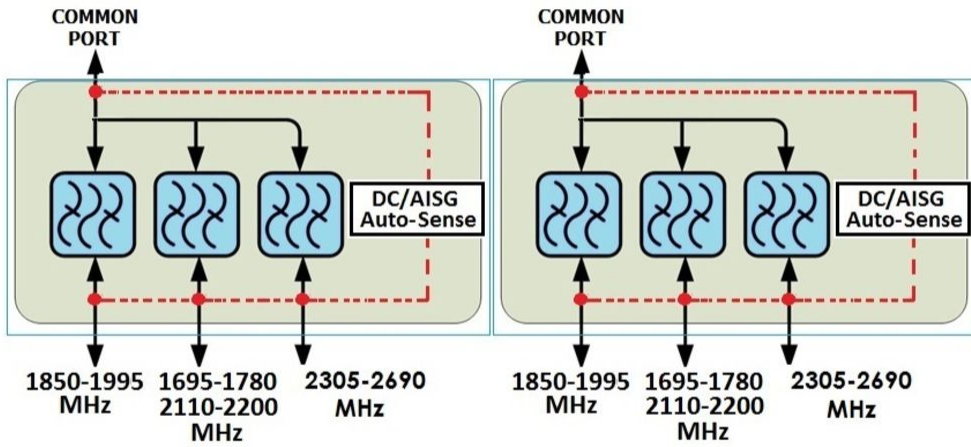

Logic Table

Combining Mode Operation (Ground Based)				
RF Ports DC Input Voltage				
Port 1 1850-1990 MHz	Port 2 1695-1780 MHz 2110-2200 MHz	Port 3 2305-2690 MHz	COMMON	DC/AISG Path Selection
<7	$7 \leq V \leq 30$	<7	<7	1695-1780 & 2110-2200 to COMMON "ON"
$7 \leq V \leq 30$	<7	<7	<7	1850-1990 to COMMON "ON"
<7	<7	$7 \leq V \leq 30$	<7	2305-2690 to COMMON "ON"
Any 2 or more ports active $7 \leq V \leq 30$			<7	Path selection will follow below priority: (1) 1695-1780 & 2110-2200 (2) 1850-1990 (3) 2305-2690

Splitting Mode Operation (Tower Top)				
RF Ports Impedance (Load Sensing)				
Port 1 1850-1990 MHz	Port 2 1695-1780 MHz 2110-2200 MHz	Port 3 2305-2690 MHz	COMMON	DC/AISG Path Selection
open/load	short	short	<7	1850-1990 to COMMON "ON"
short	open/load	short	<7	1695-1780 & 2110-2200 to COMMON "ON"
short	short	open/load	<7	2305-2690 to COMMON "ON"
Any 2 or more ports with open/load impedance			<7	DC/AISG will be routed to ALL ports with open/load impedance

Mechanical Specifications

Wind Loading at Velocity, frontal 13.0 N @ 150 km/h

Wind Loading at Velocity, lateral 13.0 N @ 150 km/h

Environmental Specifications

Operating Temperature -40 °C to +65 °C (-40 °F to +149 °F)

Corrosion Test Method IEC 60068-2-11, 30 days

Ingress Protection Test Method IEC 60529:2001, IP67

Packaging and Weights

Included Mounting hardware

CTX192126T-DS-43 | E14F60P09

Volume 2.7 L
Weight, net 4.2 kg | 9.259 lb