

Pipe Mount Kit ASPA320



GENERAL INFORMATION

The ASPA320 mounting kit consists of one clamp that is designed to secure an antennas to a wooden pole, tower leg, or mast that measures 1" to 2-7/8" in diameter. This clamp is made of gold irridite aluminum alloy.

The jaws of the ASPA320 clamp can be rotated 90° to mount onto a horizontal mounting bar. See Figure 1 for mounting configurations applicable with this mounting clamp.

PRE-INSTALLATION INSPECTION

1. After removing the antenna from the shipping box, ensure that all parts are on hand and there is no physical damage.
2. Check the antenna feed assembly output connector to determine that it mates with the end of the station transmission line. Do not remove any connectors or cables from the feed assembly as they are all part of the antenna.
3. Verify that the frequency or range to which the antenna has been tuned matches the operating frequency of the station equipment (see the packaging and the bottom of the antenna for frequency information).
4. A check of the antenna VSWR as measured at the antenna is recommended at this point. Note this measurement carefully and record it for future reference.

INSTALLATION INSTRUCTIONS

1. **For upright mount only:** (When applicable) Remove the drain plug screw located beside the connector at the base of the antenna. The drain hole must remain clear of any obstructions. Do not remove the drain plug screw at the top of the antenna. Proceed to step 3.
2. **For inverted mount only:** (When applicable) Remove the drain plug screw located at the top of the antenna. The drain hole must remain clear of any obstructions. Do not remove the drain plug screw located beside the connector at the base of the antenna. Proceed to step 3.
3. Preassemble as much of the mounting hardware as possible to the antenna while on the ground. If hoisting the antenna to the top of the tower or structure attach a rope to the mounting hardware at the bottom of the antenna and then make a slip knot loop of the rope at the top of the antenna. The slip knot loop will keep the antenna vertical when hoisting the antenna.

NOTICE

The installation, maintenance, or removal of an antenna requires qualified, experienced personnel. Andrew installation instructions are written for such installation personnel. Antenna systems should be inspected once a year by qualified personnel to verify proper installation, maintenance, and condition of equipment.

Andrew disclaims any liability or responsibility for the results of improper or unsafe installation practices.

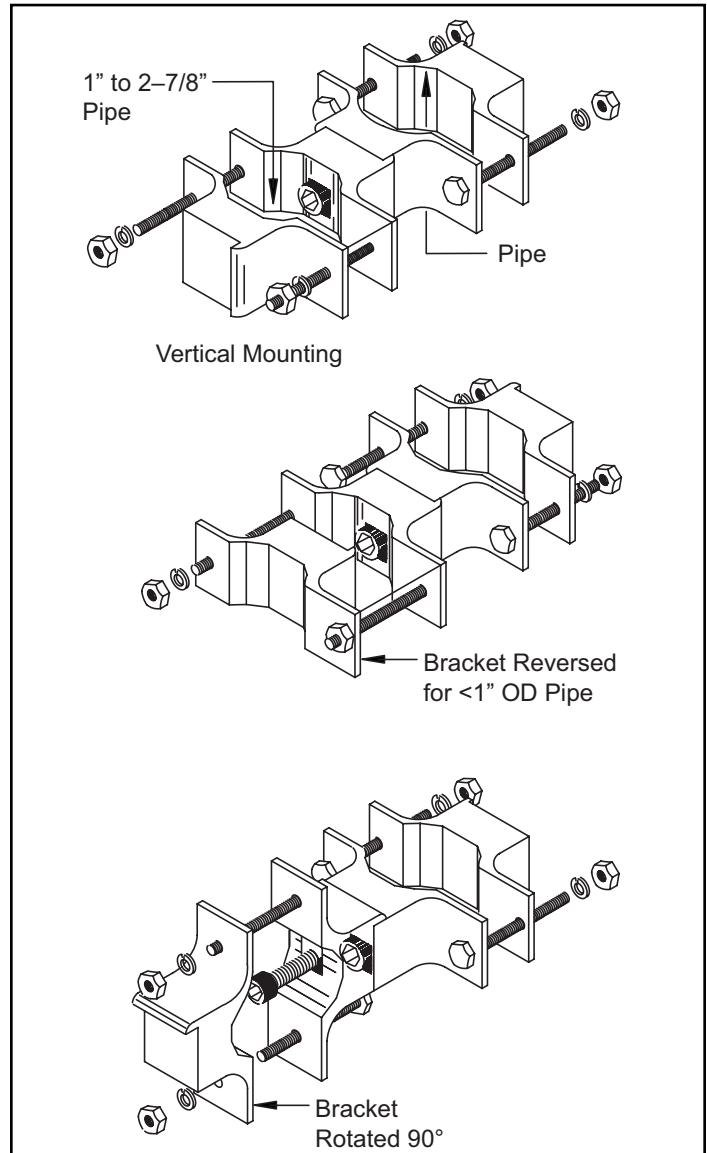

Figure 1. Possible Mounting Configurations with ASPA320 Clamp.

(continued on page 2)



Do not install near power lines. Power lines, telephone lines, and guy wires look the same. Assume any wire or line can electrocute you.



Do not install on a wet or windy day or when lightning or thunder is in the area. Do not use metal ladder.



Wear shoes with rubber soles and heels. Wear protective clothing including a long-sleeved shirt and rubber gloves.

(Continued from page 1)

For safety, an additional rope could come off the bottom of the antenna and be used as a guide by someone else on the ground.

- Securely attach the antenna to the mast or tower using the ASPA320 clamp provided. Do not overtighten the clamp; doing so will weaken the installation.

The antenna must be mounted as close to vertical as possible.

- After the antenna is secured, route the RF feed cable (not supplied) from the station equipment and attach it to the antenna. Make the connection snug, but do not apply heavy force with pliers. Andrew recommends torquing the connection to the correct torque value.

The use of a flexible pigtail (not supplied) with a mating connector is highly recommended when connecting the transmission line to the antenna. The use of a pigtail will help relieve strain on the connectors caused by flexing, expansion, and contraction of the cable.

- To avoid moisture problems, carefully weatherproof all connections, covering all cracks and the outer jacket of the transmission line. Failure to waterproof the connection may result in improper operation of the antenna.
- Properly secure the feeder cable and transmission line to the tower in the best position to avoid physical damage to the cable.

POST-INSTALLATION INSPECTION

After the antenna and transmission line have been installed, a careful visual check should be made to ensure that:

- All mechanical connections have been made
- The antenna is mounted as close to vertical as possible
- The proper mount was achieved—either upright or inverted
- The drain hole is clear of all obstructions
- All connections have been carefully wrapped to prevent moisture problems

Tighten all hardware.

Torque:

5/16–18 = 134 IN-LBS (15 N-M)

1/2–13 = 516 IN-LBS (58 N-M)