

DRAWING NO.
10052202

CATALOG NUMBER	ITEM NUMBER	COLOR CODE	DIE INFORMATION		BURNDY INSTALLATION TOOLING (# CRIMPS)								WIRE STRIP LENGTH	
			DIE INDEX	TYPE	MECHANICAL				HYDRAULIC					
					OUR840	MD6 MD7	MD6--R2	MD7-34R	Y500CT BCT500	Y35, Y39 Y750, Y46 PAT750	Y45	DIELESS (# CRIMPS)		
YAV2CL-4TC14FXG1	10050820	BROWN	10	BROWN DIE SET	X2CRT(1)	W2CRT(1) W2CVT(1)	W2CRT(1) W2CVT(1)	W2CRT(1) W2CVT(1)	W2CRT(1) W2CVT(1)	W2CRT(1) W2CVT(1)	U2CRT(1)	U2CRT(1)	MECHANICAL: MY29-3 (1) MY29-11(1)	11/16"
YAV25L-4TC14FXG1	10037859	PINK	12 348	PINK DIE SET	X25RT(2)	W25RT(2) W25VT(2)	W25RT(2) W25VT(2)	W25RT(2) W25VT(2)	X25RT(2) W25VT(2)	U25RT(1)	U25RT(1)		13/16"	
YAV26L-4TC14FXG1	10037860	BLACK	13	BLACK DIE SET	X26RT(2)	W26RT(2) W26VT(2)	W26RT(2) W26VT(2)	W26RT(2) W26VT(2)	X26RT(2) W26VT(2)	U26RT(1)	U26RT(1)	HYDRAULIC: Y644HSXT-18V (1) PAT644XT-18V (1)	1-1/16"	
YAV27L-4TC14FXG1	10052263	ORANGE	14	ORANGE DIE SET	X27RT(3)	W27RT(2) W27VT(2)	W27RT(2) W27VT(2)	W27RT(2) W27VT(2)	W27RT(2) W27VT(2)	U27RT(1)	U27RT(1)		(1)-1/16"	
YAV28L-4TC14FXG1	10037858	PURPLE	15	PURPLE DIE SET	X28RT(3)	W28RT(2) W28VT(2)	W28RT(2) W28VT(2)	W28RT(2) W28VT(2)	X28RT(2) W28VT(2)	U28RT(1)	U28RT(1)		11/16"	

REV.	DATE	DESCRIPTION	ECO	BY	C'K'D.
D	5/5/2014	UPDATE TYPES.	36014	BSB	VK

CATALOG NUMBER	ITEM NUMBER	COPPER CONDUCTOR ACCOMMODATED			BOLT SIZE	METRIC BOLT SIZE	DIMENSIONS			
		FLEX	CODE (AWG)	NAVY			B ±.08	L ±.12	O.D. ±.01	T REF
YAV2CL4TC14FXG1	10050820	#2 WELD 125/24, 150/24	#2 AWG	60	1/4	M6	.62 [16]	2.84 [71]	.46 [12]	.11 [2]
YAV25L4TC14FXG1	10037859	1/0 WELD 275/24	1/0 AWG	100	1/4	M6	.69 [18]	2.90 [74]	.56 [14]	.21 [5]
YAV26L4TC14FXG1	10037860	2/0 WELD 325/24	2/0 AWG	125	1/4	M6	.81 [21]	3.07 [78]	.51 [13]	.21 [5]
YAV27L4TC14FXG1	10052263	3/0 WELD 450/24	3/0 AWG	150	1/4	M6	1.00 [25]	3.30 [84]	.70 [18]	.21 [5]
YAV28L4TC14FXG1	10037858	4/0 WELD 550/24	4/0 AWG	200	1/4	M6	1.03 [26]	3.38 [86]	.77 [20]	.21 [5]

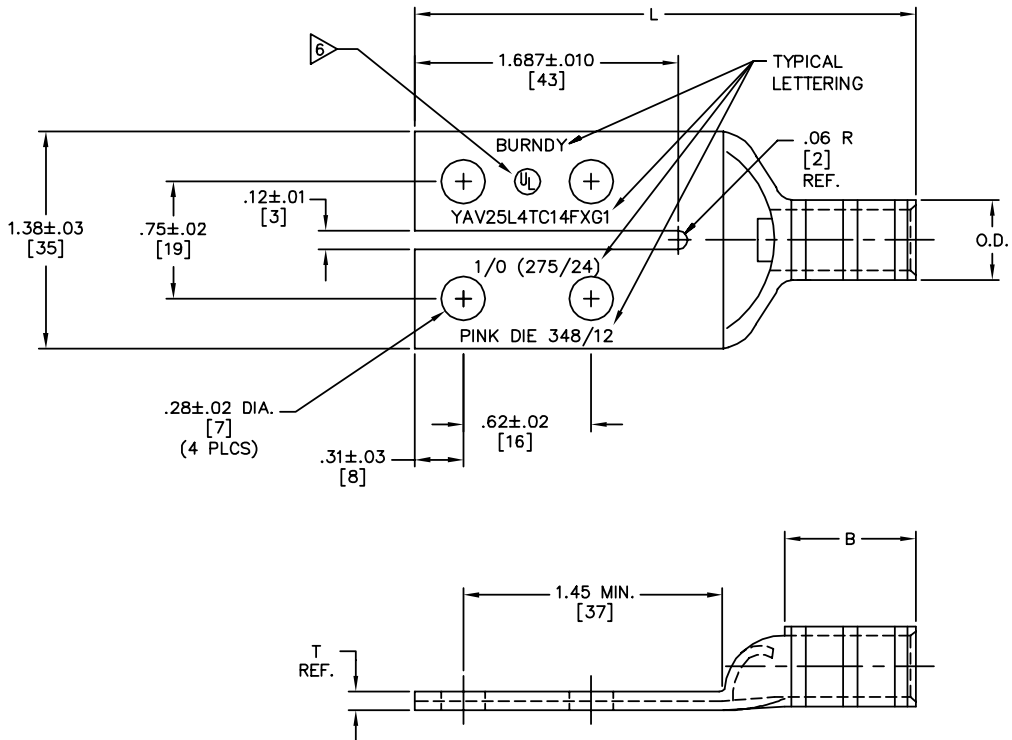

NOTES:

- MATERIAL: COPPER
- FINISH: TIN PLATED
- CATALOG # PT6515 ADAPTOR IS REQUIRED TO USE "U" DIES IN Y45 SERIES TOOLS.
- CATALOG # PUADP-1 ADAPTOR IS REQUIRED TO USE "U" DIES IN Y46 SERIES TOOLS.
- DIMENSIONS IN BRACKETS [] ARE IN MILLIMETERS ROUNDED OFF TO THE NEAREST MILLIMETER, UNLESS OTHERWISE NOTED, AND ARE FOR REFERENCE ONLY.
- UL 486A LISTED, FILE NO.E9498.

TO ORDER BURNDY® PRODUCTS CALL
 UNITED STATES:
 1-800-346-4175 (LONDONDERRY, NH)
 CANADA:
 1-800-361-6975 (QUEBEC)
 1-800-387-6487 (ALL OTHER PROVINCES)
 FOR PRODUCT INFO: <http://www.burndy.com>

HYLUG™ (4 HOLE-SPLIT PAD) FLEX	
ITEM NO: (TABLE)	
CAT NO: YAV--L-4TC--FXG1 (TABLE)	
SCALE: NTS	
DRAWN BY: D. BOISVERT	12/28/04
CHECKER: J. MICHAUD	12/30/04
DSN APPVL: J. MICHAUD	12/29/04
MFG APPVL: N/A	--
QC APPVL: J. BRODEUR	12/30/04
MKT APPVL: G. SCHWEBLER	01/04/05
PROJ FAM: --	
PROJECT #: --	
DOCUMENT TYPE: Sales	
REL LEVEL: AutoCAD	
DRAWING NO	REV
10052202	D
SHEET 1 of 1	